

- SOD-372420 has 19" EIA standard rails, 19RU long.
- New style poly filter and frame (see reference drawing DR-00031)
- Two 1/4-20x.625 studs attached to right side, below side plate, for attaching optional 110V receptacle(s).
- Standard Knockouts in cabinet floor in standard locations.
- EMKA pad locking handle with 3 point locking.
EMKA P/N: 1000-U32
- Side plate shall attach to the cabinet with #8-32 countersunk screws. PEM nuts will be attached to the interior of the cabinet.
- There will be a 1/4"-20x.5" ground stud 1" from the back of the cabinet and 1" from the right side, in the floor of the enclosure.
- Door will have upper and lower rod guide BOTH 1.75" brackets in dimensioned locations.
- Fan ducting will be mounted to side plate as standard part and location.

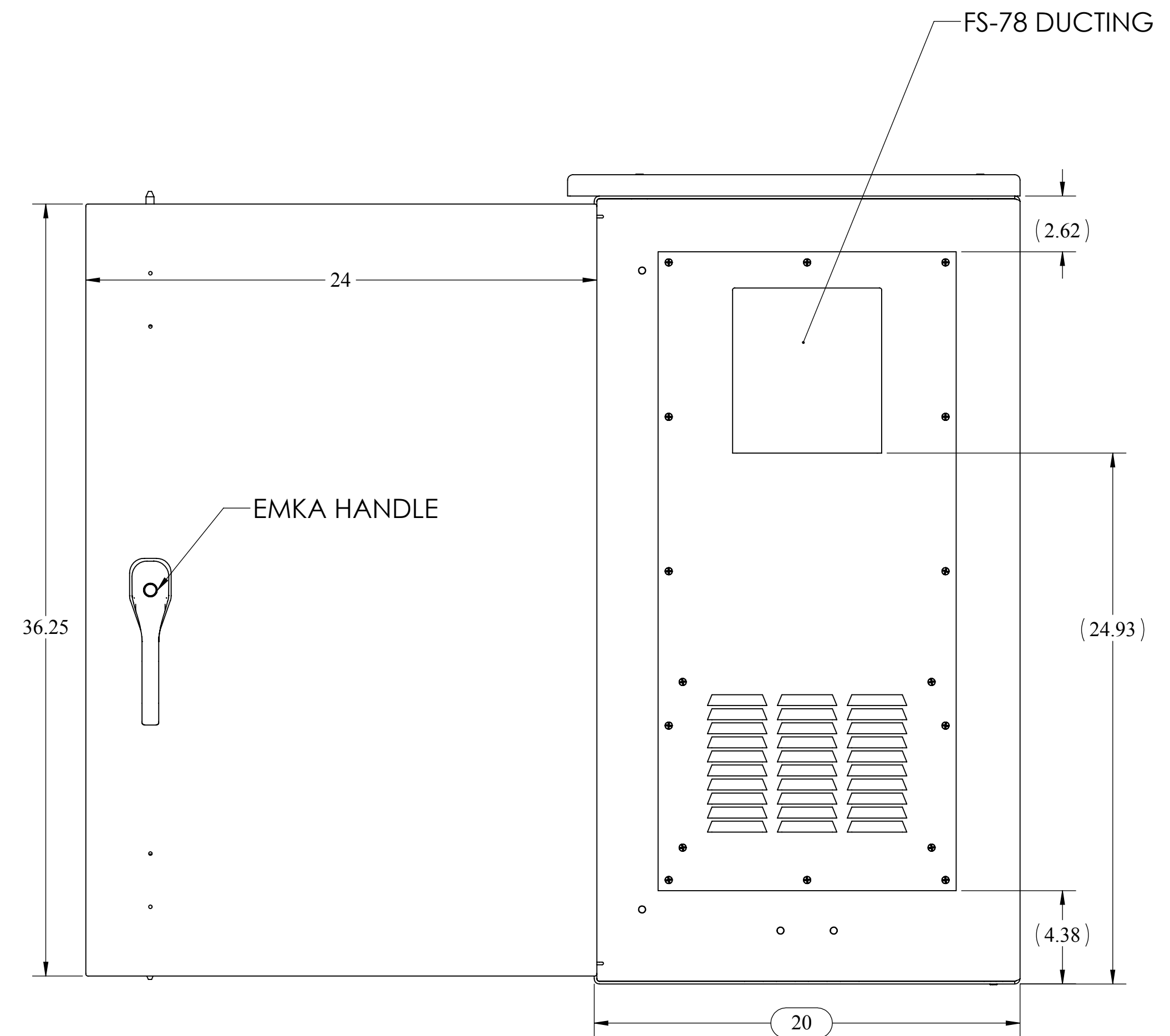
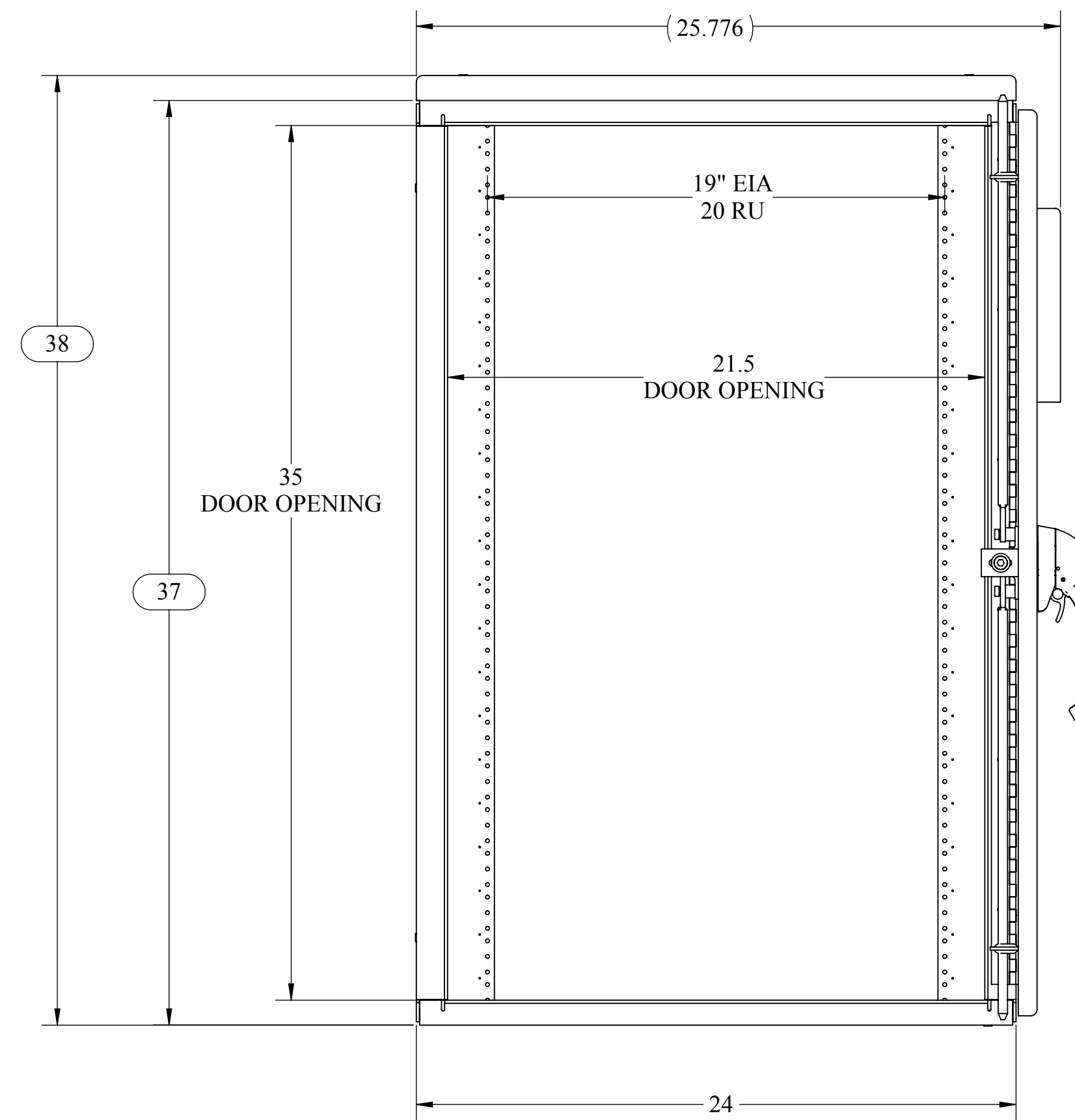
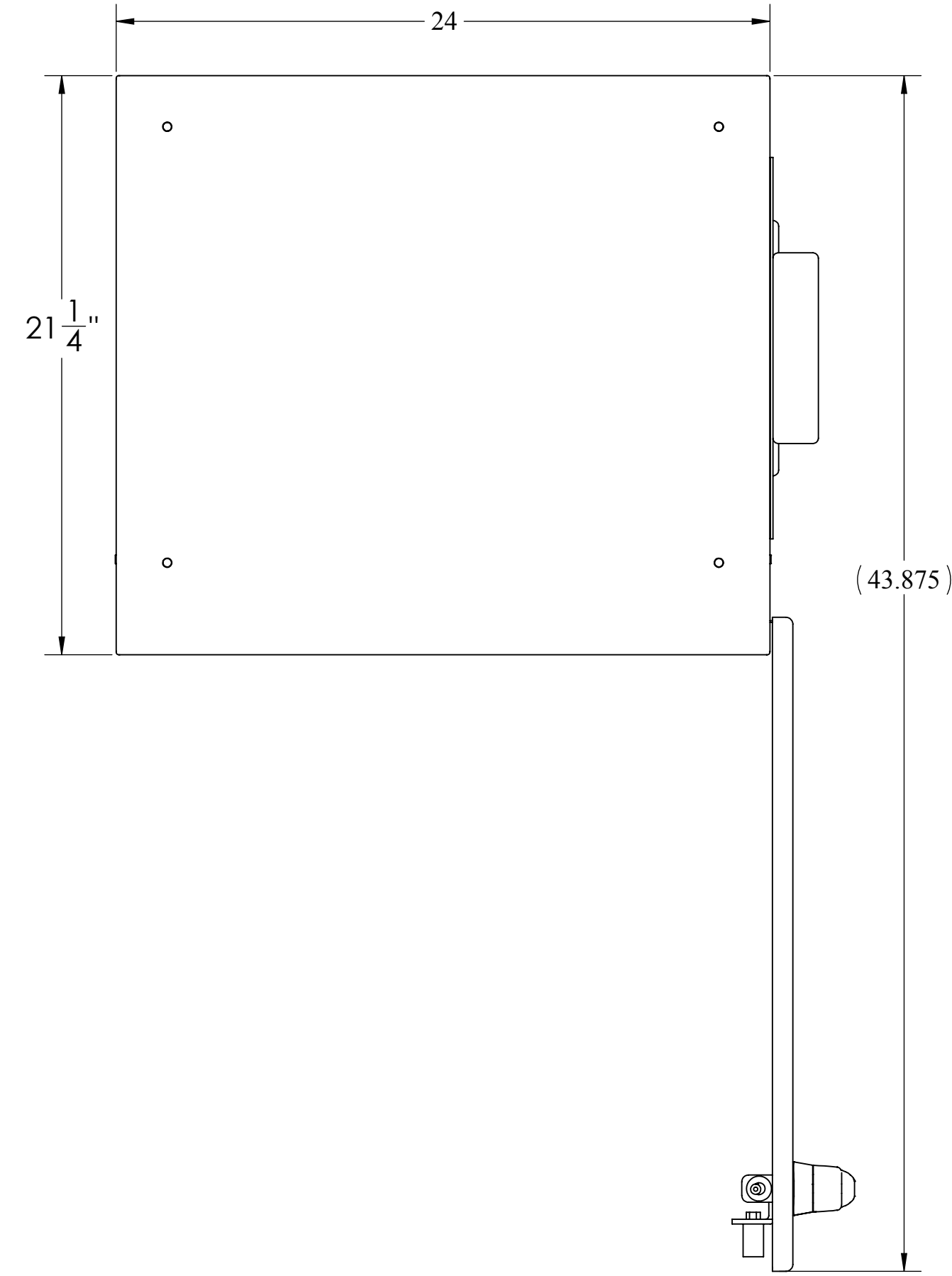
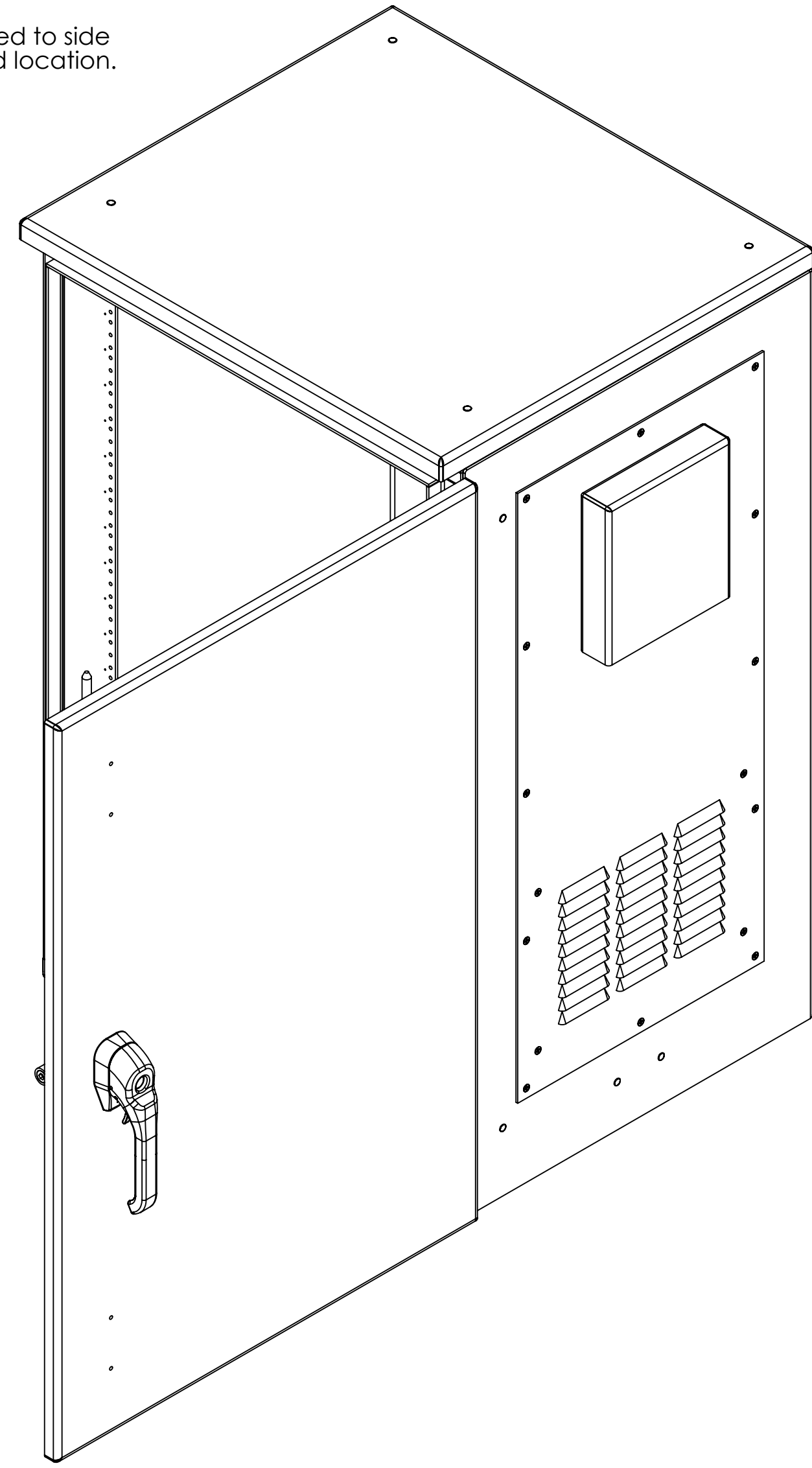

REVISIONS		
REV.	DESCRIPTION	DATE
A	Initial Release per DR-00068	6/17/2011
B	Update per DR-00531 ADDED EMKA HANDLE AND DOOR RODS, BRACKETS & FS-78 DUCTING. UPDATED DEPTH OF ALUMASHIELD TO 21 1/4", UPDATED SIDE PANEL CUTOUT TO 5 1/8" FROM BASE.	12/17/2012

NOTES: UNLESS OTHERWISE SPECIFIED

- DIMENSIONS AND TOLERANCES ARE IN ACCORDANCE WITH ASME Y14.5M
- DIMENSIONS ARE IN INCHES, UNLESS OTHERWISE SPECIFIED
- THIS IS A SUPPLEMENTAL DRAWING AND MAY NOT BE FULLY DIMENSIONED. THE NOTES, TOLERANCES, AND SPECIAL INSTRUCTIONS ARE TO BE USED ALONG WITH THE LATEST REVISION OF THE SOLID DATABASE. THE PART OR ASSEMBLY IS TO BE CONTROLLED PER THE ELECTRONIC FILE.
- SYMBOL DENOTES CRITICAL DIMENSIONS AND MUST BE INSPECTED.
- REMOVE ALL BURRS AND SHARP EDGES 0.025" MAX RADIUS OR CHAMFER
- DO NOT DEBURR PRESS FIT HOLES
- DIMENSIONS SHALL APPLY AFTER ALODINE, PAINT, FINISH, OR COAT IS APPLIED
- INSTALL PRESS FIT STANDOFFS, STUDS, AND NUTS IN ACCORDANCE WITH THE MANUFACTURER'S SPECIFICATIONS.
- IDENTIFY PART WITH PART NUMBER, REVISION LETTER AND SERIAL NUMBER
- FINISHED PART TO BE FREE OF OILS, LUBRICANTS, AND OTHER CONTAMINANTS
- TOLERANCES, UNLESS OTHERWISE SPECIFIED.
 - HOLE SIZE: +/- 0.003"
 - HOLE TO HOLE: +/- 0.005"
 - HOLE TO EDGE: +/- 0.010"
 - HOLE TO FOLD: +/- 0.015"
 - FOLD TO FOLD: +/- 0.020"



UNLESS OTHERWISE SPECIFIED:		NAME	DATE	DDB Unlimited Inc.		
DIMENSIONS ARE IN INCHES		Model by:	DDR	SOD-372420		
ANGULAR:	±1°	Drawn by:	MarvinS	SIZE	Cage Code:	DWG. NO.:
FRACTIONAL/NO DECIMAL:	±0.1250	Sales.Rep.:	SteveA	D	385Y5	DR-00068
ONE PLACE DECIMAL:	±0.0625	Prod.Mgr.:	ClarkK	SCALE: 1:2	WEIGHT: 69 lbs.	REV B
TWO PLACE DECIMAL:	±0.03125	MATERIAL: VARIES		Control Number:	SHEET 1 OF 7	
THREE PLACE DECIMAL:	±0.015625	PAINT: VARIES				
FOUR PLACE DECIMAL:	±0.0078125	DO NOT SCALE DRAWING				

PROPRIETARY AND CONFIDENTIAL
 THE INFORMATION CONTAINED IN THIS DRAWING IS THE SOLE PROPERTY OF DDB Unlimited, INC. ANY
 REPRODUCTION IN PART OR AS A WHOLE WITHOUT THE WRITTEN PERMISSION OF DDB Unlimited, INC. IS PROHIBITED.

8 7 6 5 4 3 2 1

H
G
F
E
D
C
B
A

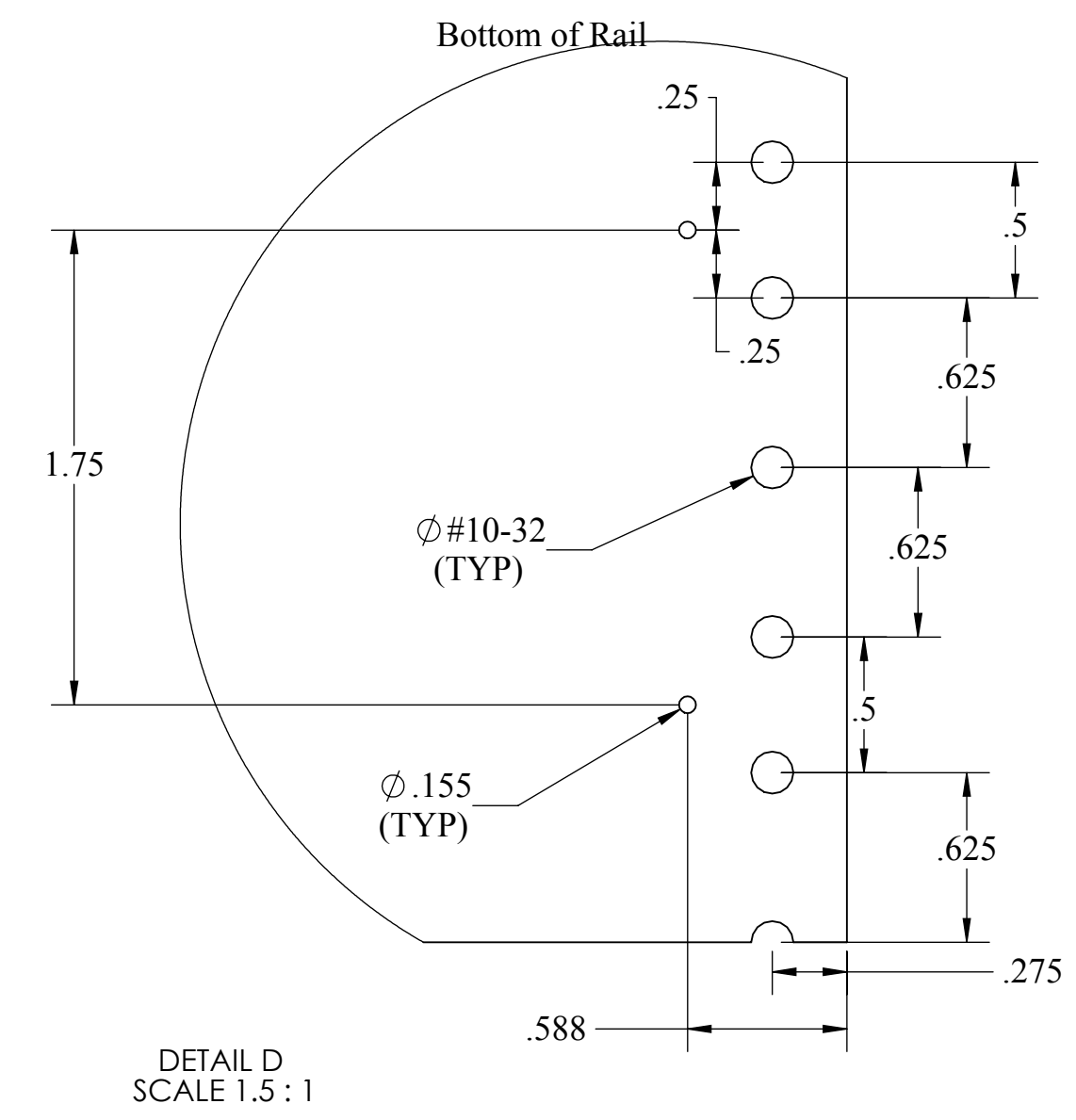
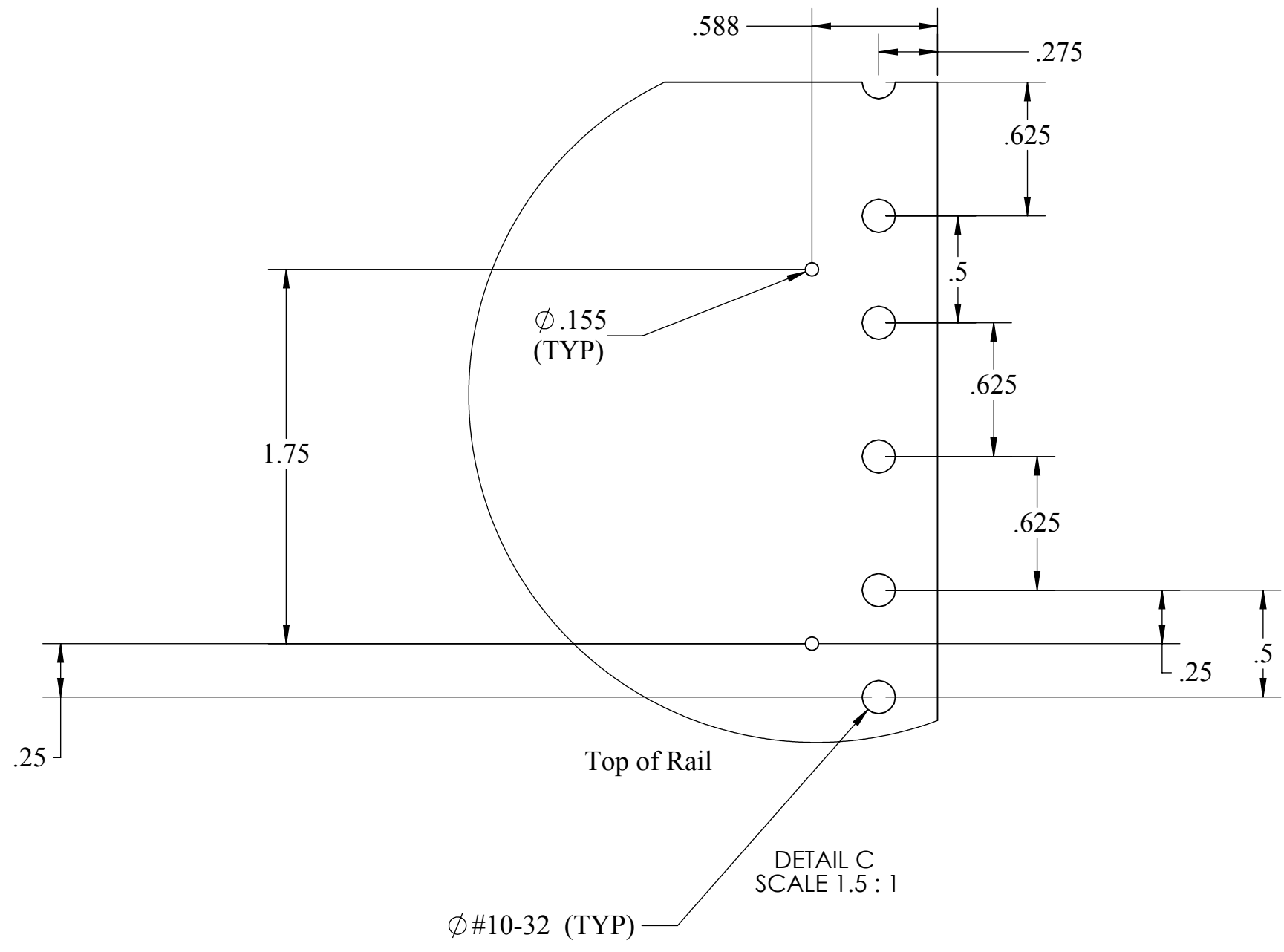
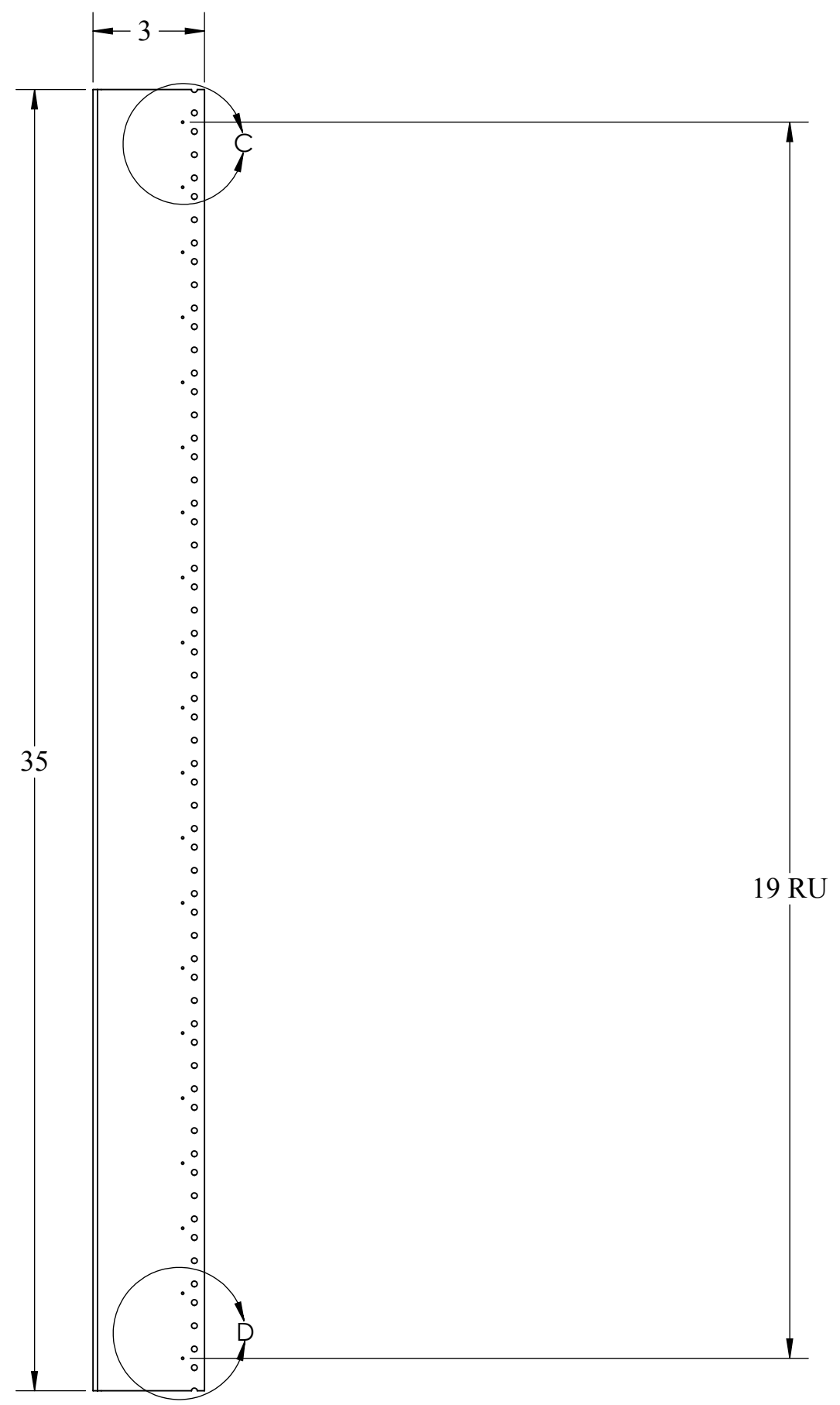
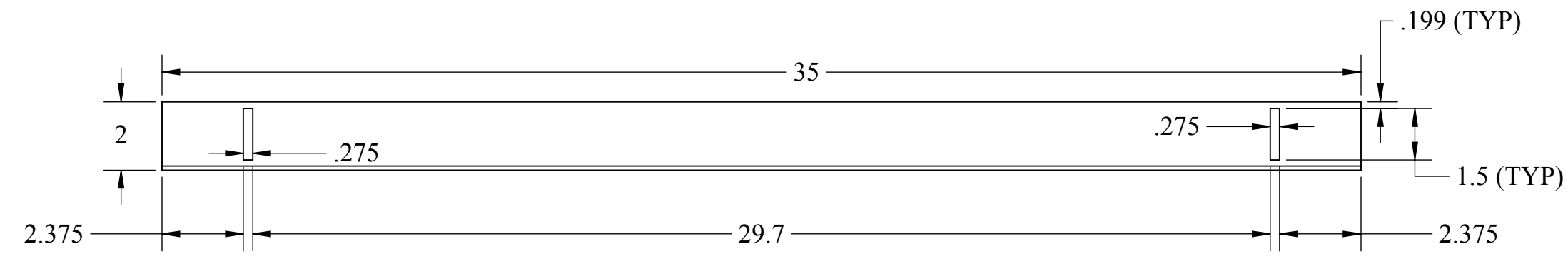
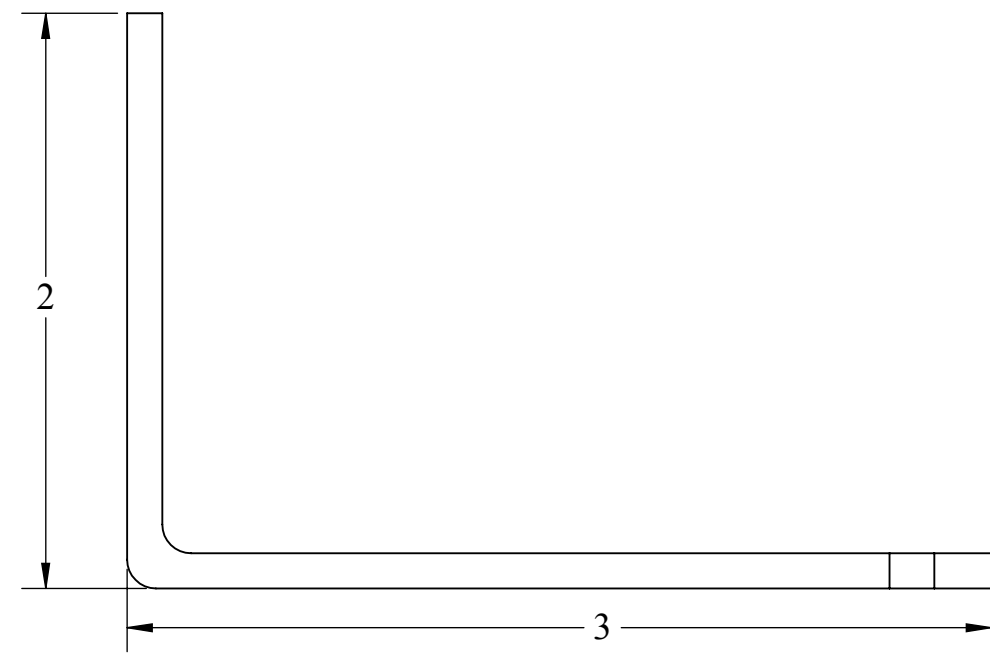

DDB Unlimited Inc.			
SOD-372420 19" Rail			
SIZE	Cage Code:	DWG. NO.:	REV
D	385Y5	DR-00068	B
SCALE: 1:2		WEIGHT: lbs.	SHEET 6 OF 7

MATERIAL: Varies
PAINT: Varies
DO NOT SCALE DRAWING

PROPRIETARY AND CONFIDENTIAL
 THE INFORMATION CONTAINED IN THIS DRAWING IS THE SOLE PROPERTY OF DDB Unlimited, INC. ANY
 REPRODUCTION IN PART OR AS A WHOLE WITHOUT THE WRITTEN PERMISSION OF DDB Unlimited, INC. IS PROHIBITED.

DDB FORM: 7-1-2 REV. C 10/01/12