

The WCU-B14 is a Wireless Control Unit. This enclosure has two compartments. The larger compartment is the vented battery section. The smaller compartment is divided. This is the radio section with an I/O section. The I/O section has a hole for cable entry. The battery compartment has 4 hole in the side for wall mounting. The removable plate between the two compartments have a pair of battery cable pass through holes. The lid and door to the enclosure are secured by padlocks.

There are fan kit and heating options available for this enclosure.

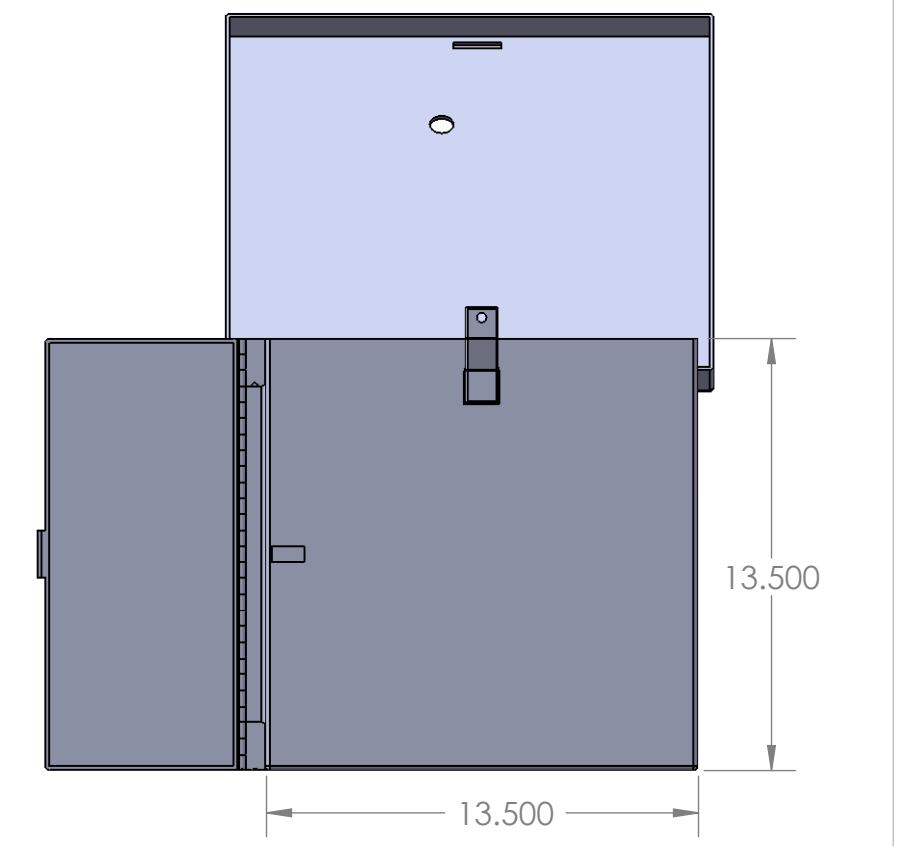

PROPRIETARY AND CONFIDENTIAL:
 THE INFORMATION CONTAINED IN THIS DRAWING IS THE SOLE PROPERTY OF DDB Unlimited, INC. ANY REPRODUCTION IN PART OR AS A WHOLE WITHOUT THE WRITTEN PERMISSION OF DDB Unlimited, INC IS PROHIBITED.

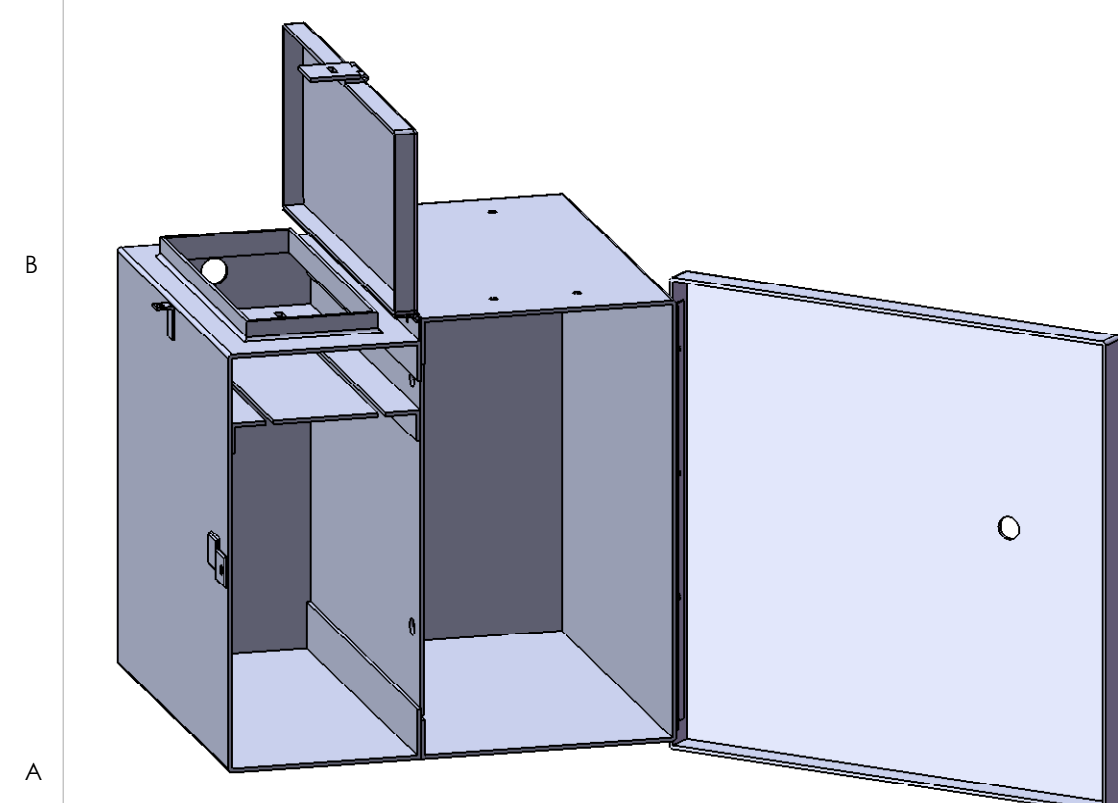

Dimension:	Dimension Unit:	UNLESS OTHERWISE SPECIFIED: DIMENSIONS ARE IN INCHES	DRAWN:	R. Lamson	DATE:	12/28/2007	DDB Unlimited Inc.		
Height:	14 inches	DO NOT SCALE DRAWING	CHECKED:						
Width:	14.5 inches	MAJOR MATERIAL: Aluminum	ENG APPR:				SIZE	DWG. NO.	VER.
Depth:	14.25 inches		MFG APPR:				A	00001	1
Color:	Powder Baked Cream		Q&A:				Scale= 1: 6	Weight:~20 lbs	Sheet 1 of 1
			COMMENTS: 1. Unless otherwise noted, Material Thickness is 1/8 (.125) inches thick.						