

IQ5500VS SPEC DRAWINGS REV 0

COOLING CAPACITY: 5500 BTUH @131°F
 MAXIMUM AMPS: 10.1 @120V/60HZ
 MAXIMUM AMPS: 5.0/5.5 @230/220 60/50HZ
 MAXIMUM OPERATING TEMP.: 131°F
 DIMENSIONS: 30.09"H X 12.27"W X 10.39"D
 WEIGHT: 75 LBS

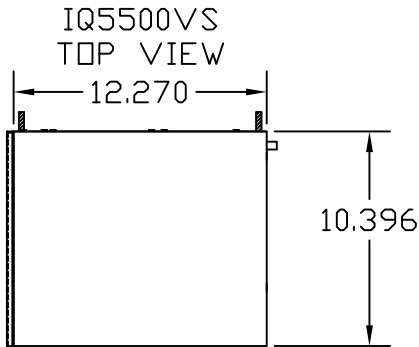

IQ5500VS
LEFT SIDE

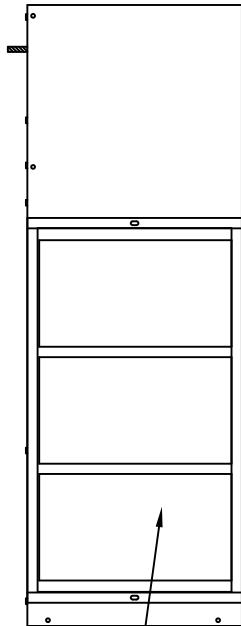

CONDENSER
AIR INLET

IQ5500VS
FRONT VIEW

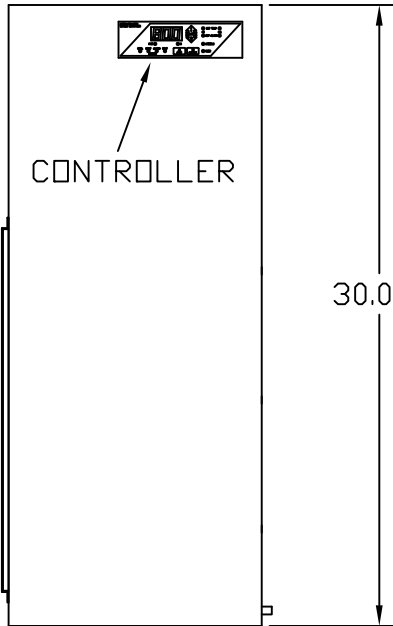

IQ5500VS
RIGHT SIDE

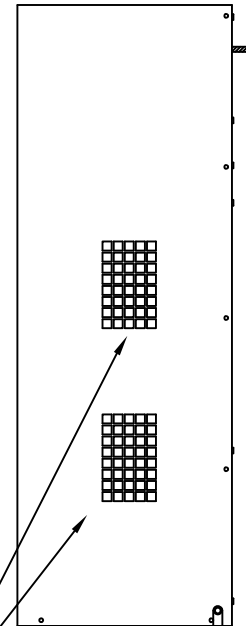

CONDENSER
AIR OUTLETS

PROPRIETARY DRAWING
 THIS DRAWING IS THE PROPERTY OF ICE
 QUBE, INC. AND IS NOT TO BE REPLICATED
 OR ALTERED WITHOUT AUTHORIZATION OF
 ICE QUBE, INC.

DRAWN J.J.H. SCALE NONE
 DATE 2-15-10
 SHEET 2 OF 2

Ice Qube INDUSTRIAL COOLING EQUIPMENT
 141 WILSON AVENUE
 GREENSBURG, PA 15601
 724-837-8204 • 1-888-867-8234
 FAX 724-837-9386

IQ5500VS

IQ300216 0

IQ5500VS
REAR VIEW

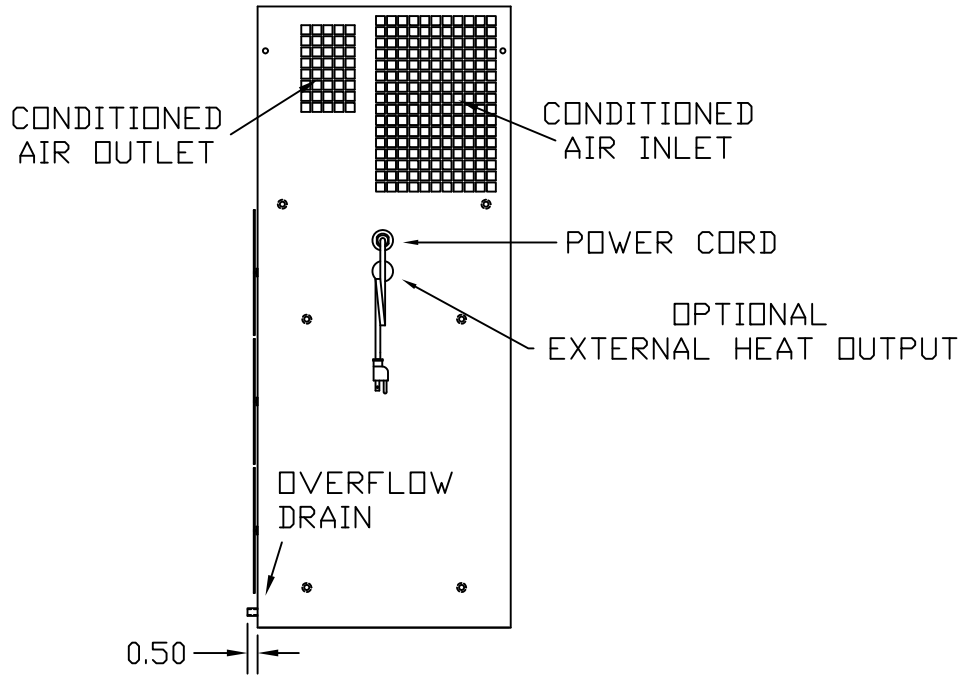

IQ5500VS
CUTOUT DRAWING

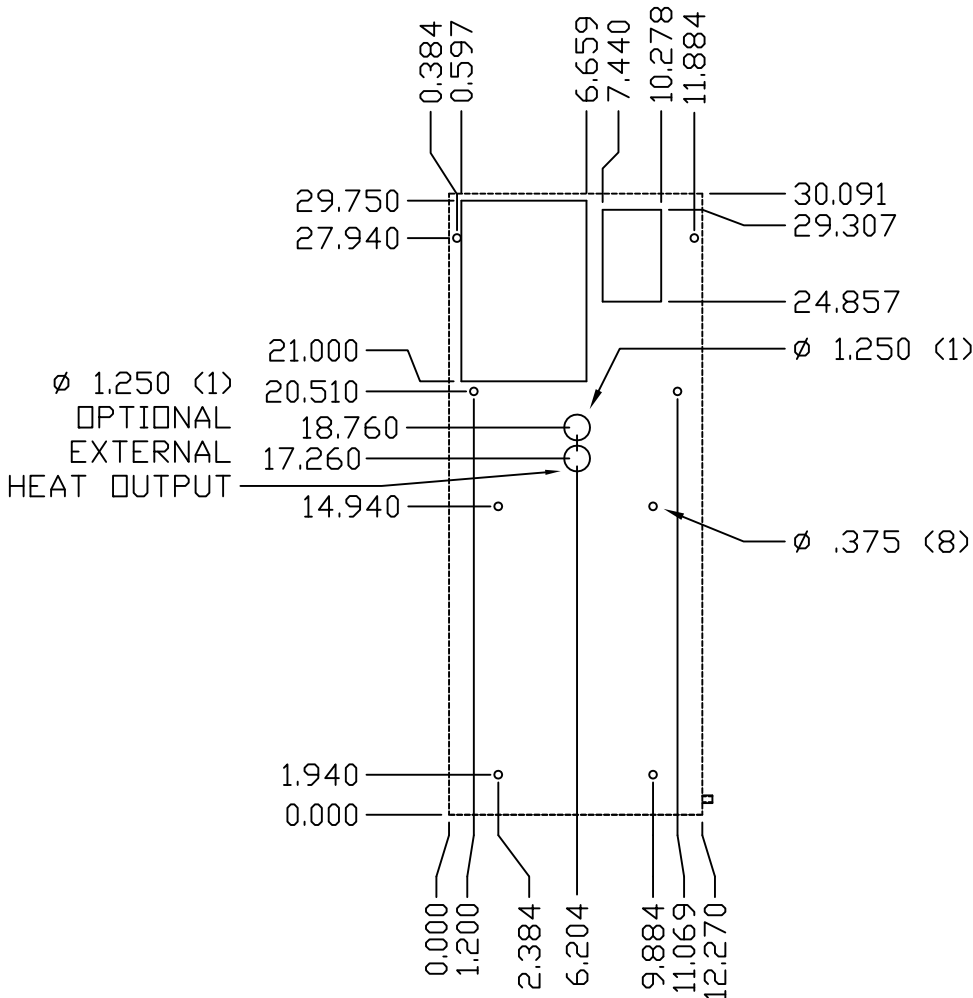

IQ5500VS
GASKET DRAWING

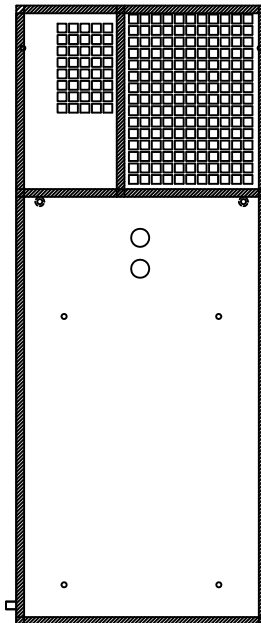

IMPORTANT
GASKET MUST BE
APPLIED AS SHOWN
FOR PROPER OPERATION
AND TO MAINTAIN
NEMA INTEGRITY.

0	INITIAL RELEASE	2-15-10	JJH
REV	DESCRIPTION	DATE	CHECKED
	REVISIONS		

PROPRIETARY DRAWING
THIS DRAWING IS THE PROPERTY OF ICE
CUBE, INC. AND IS NOT TO BE REPLICATED
OR ALTERED WITHOUT AUTHORIZATION OF
ICE CUBE, INC.

DRAWN JJH SCALE NONE
DATE 2-15-10
SHEET 1 OF 2

Ice
Cube
INDUSTRIAL COOLING EQUIPMENT
141 WILSON AVENUE
GREENSBURG, PA 15601
724-837-8204 • 1-888-867-8234
FAX 724-837-9286

IQ5500VS

IQ300216 0