



Enclosure Manual

# **DDB Unlimited, Inc.**

**Manual for the LTEE-D Enclosure**

**5/7/2013**

**Version 2; RHD**

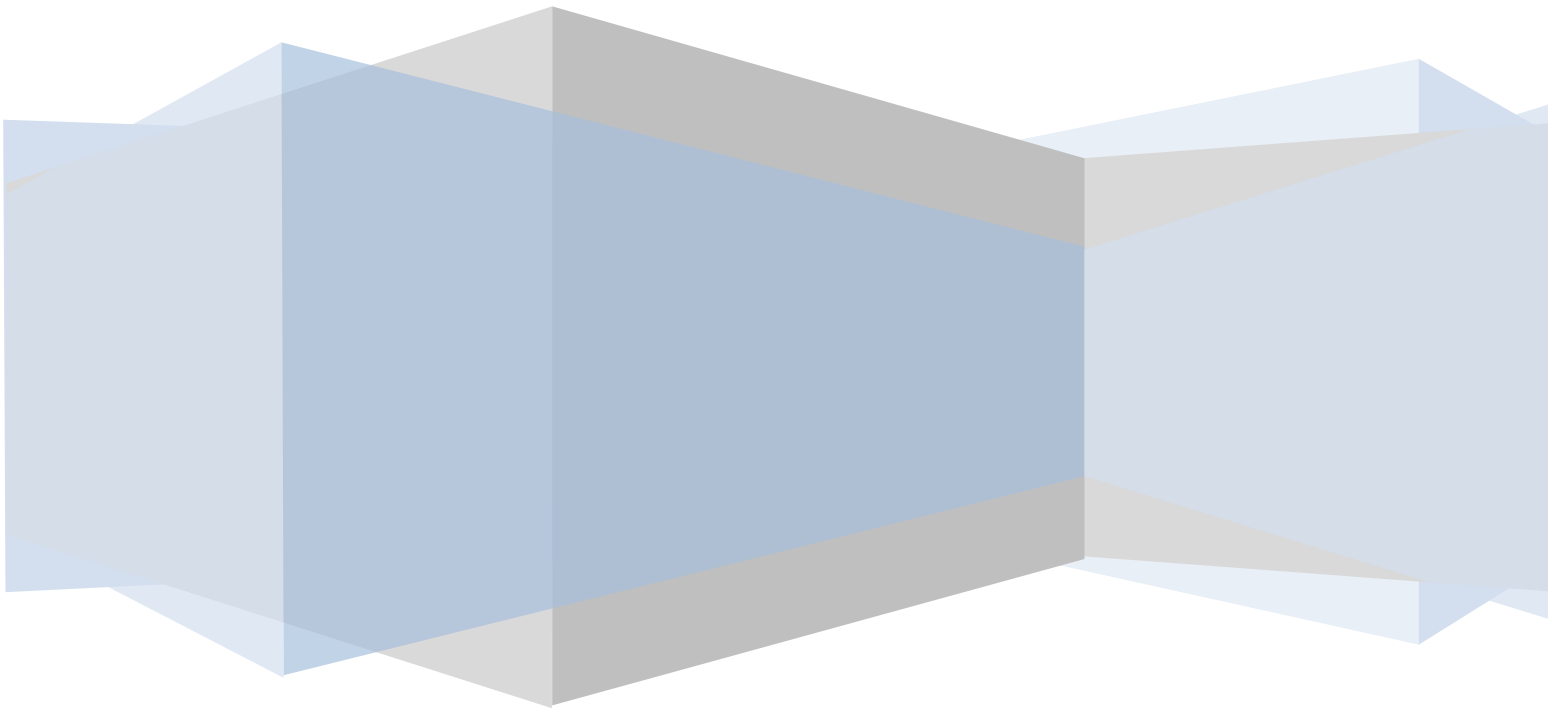

## TABLE OF CONTENTS

<b>1 INTRODUCTION</b>	<b>4</b>
1.1 PURPOSE	4
1.2 CONTENT AND ORGANIZATION	4
1.3 ETL CERTIFICATION	4
<b>2 ENCLOSURE OVERVIEW</b>	<b>4</b>
2.1 MATERIAL	4
2.2 POWDER COAT SPECIFICATION	5
2.3 CABINET CONFIGURATION	6
2.3.1 DIRECT AIR COOLED UNIT LTEE-D	6
2.3.2 INTAKE FILTER DETAILS	8
2.3.3 FILTER SPECIFICATIONS	11
2.3.4 CABINET VIEWS AND OVERALL DIMENSIONING	13
2.3.5 BASE CABINET SPECS	15
2.3.6 PAD MOUNTING DETAILS	15
2.3.7 EXHAUST FAN DETAILS	16
<b>3 ELECTRICAL &amp; GROUNDING OVERVIEW</b>	<b>18</b>
3.1 ELECTRICAL SCHEMATICS	18
3.2 PANEL SCHEDULE	20
3.3 GROUND BAR	21
3.4 GROUND BAR ASSEMBLY DETAIL	22
<b>4 RACK RAILS OVERVIEW</b>	<b>23</b>
4.1 RACK RAILS	23
<b>5 BATTERY BOX &amp; SIDE BOX OVERVIEW</b>	<b>25</b>
5.1 BATTERY BOX EXHAUST FANS	25
5.2 SIDE BOX DETAIL	26
<b>6 APPENDICES</b>	<b>27</b>
6.1 ENCLOSURE WARRANTY	27

<b>7 FIGURES</b>		
1	BASIC COMPONENT BREAKDOWN FOR THE LTE ENCLOSURE	6
2	BASIC AIRFLOW AND CLIMATE CONTROL DESCRIPTION	6
3	DIRECT AIR COOLED DESCRIPTION	7
4	OUTSIDE VIEW OF FRONT DOOR WITH CUTOUTS FOR THE INTAKE	8
5	INTAKE CUTOUTS ON FRONT DOOR	10
6	FILTER DESCRIPTION	11
7	FILTER SCHEMATIC DRAWING AND NOTES	12
8	ISOMETRIC VIEW OF THE LTEE-D	13
9	FRONT DIMENSIONAL VIEW OF THE LTEE-D	13
10	RIGHT SIDE VIEW OF THE LTEE-D	14
11	LEFT SIDE VIEW OF THE LTEE-D	14
12	TOTAL OCCUPIED SPACE OF THE LTEE-D	14
13	PADMOUNTING DETAIL	15
14	REAR DOOR EXHAUST FAN AIRFLOW	16
15	FAN CURVE AND SPECIFICATIONS	16
16	GENERAL FAN SPECIFICATIONS	17
17	ANSI TITLE BLOCK, ELECTRICAL SCHEMATIC PG. 1	18
18	ANSI TITLE BLOCK, ELECTRICAL SCHEMATIC PG. 2	19
19	12" GROUNDBAR	21
20	GROUNDBAR ASSEMBLY DETAIL	22
21	RACK RAIL DETAIL	23
22	DETAIL "F" OF THE RACK RAIL DETAIL	24
23	½" GROUND STRAP FOR THE LTE SERIES RACK RAILS	24
24	DC AXIAL EXHAUST FANS	25
25	SIDE BOX DETAIL & DIMENSIONS	26
<b>8 TABLES</b>		
1	HOLE LOCATION TABLE FOR THE FRONT DOOR OF THE LTEE-D	9
2	INTAKE FILTER SPECIFICATIONS	11
3	PANEL SCHEDULE FOR BOTH THE LTEE-A & LTEE-D	20

# 1 INTRODUCTION

## 1.1 PURPOSE

This document is intended to describe the LTEE-D (Direct Air Cooled) enclosure.

## 1.2 CONTENT AND ORGANIZATION

This document consists of 6 chapters including Appendices, Figures and Tables.

## 1.3 ETL CERTIFICATION

This document section will contain excerpts from ETL DRAFT Report No.100393104DAL-001, issued for review on: 27-May-2011. A full copy of the ETL listing report can be obtained by contacting DDB Unlimited. This Section is to be completed upon final ETL certification.

# 2 ENCLOSURE OVERVIEW

## 2.1 MATERIAL

The ASTM B209-04 is the material standard for our Aluminum class 5052h32 manufacture. ASTM B209-04 can be sold and or used in special fire rated categories such as fire block between buildings or fire protection of critical supports.

The standard flash point of 5052h32 is 606 degrees C. Aluminum 5052h32 is considered RoHS compliant by both American and European Standards agencies.

Reference: ASTM B209-04 "standard Specification for Aluminum and Aluminum-Alloy Sheet and Plate"

### ■ Aluminum temper designation

Aluminum is specified with a 4 digit alloy followed by a temper designation. For example, 5052-H32 indicates an aluminum/magnesium alloy that has been strain hardened and stabilized by low temperature heating and is 1/4 hard.

-H	Strain hardened (cold worked) with or without thermal treatment.
-H1	Strain hardened without thermal treatment.
-H2	Strain hardened and partially annealed.
-H3	Strain hardened and stabilized by low temperature heating.
2nd Digit	A second digit denotes the degree of hardness. -Hx2 = 1/4 hard. -Hx4 = 1/2 hard. -Hx6 = 3/4 hard. -Hx8 = full hard.

## 2.2 POWDER COAT SPECIFICATION – Provided by Diamond Vogel.

**TECHNICAL DATA**

PRODUCT CODE: PLX4372-09

DATE: March 23, 2009

PRODUCT DESCRIPTION: White Gloss Texture

POWDER CLASS: TGIC Polyester

**POWDER PROPERTIES**Specific Gravity 1.86 Theoretical Coverage (ft<sup>2</sup>/lb) @ 1 mil: 103 ± 4**CURED POWDER PROPERTIES (1.8 TO 2.2 Mils DFT)**

Cure Schedule (Time at Substrate Temperature)	<u>10' @ 390°F</u>
Substrate for testing	<u>B-1000 .032 in CRS</u>
Gloss	<u>40 +/- 10 @ 60°</u>
PCI Powder Smoothness	<u>Texture</u>
Pencil Hardness	<u>2H+</u>
Direct/Reverse Impact in. lbs.	<u>160+ / 160+</u>
Adhesion, Crosshatch	<u>5B</u>
Flexibility, Mandrel Bend	<u>1/8 in dia. no fracture</u>
Salt Spray ASTM-B117 1000 hrs.	<u>Pass</u>
Humidity ASTM-D2247 1000 hrs.	<u>Pass</u>

**Additional Technical Data available upon request**

## 2.3 CABINET CONFIGURATION

### 2.3.1 DIRECT AIR COOLED UNIT: LTEE-D

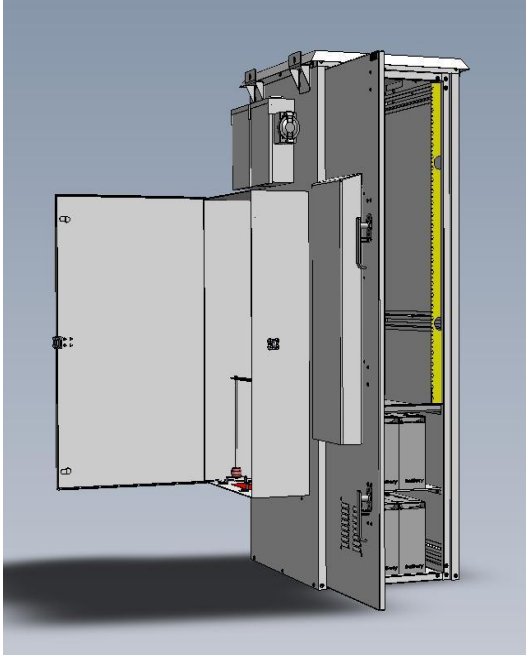

#### DESCRIPTION

- Outdoor enclosure 80”H x 25”W x 34”D with front and rear doors.
- Adjustable 19” or 23” racking, 2 sets front and rear.
- Powder baked white.
- Dual compartment design, 600 cfm direct air cooled (DAC) top compartment and fan cooled battery compartment using (2) 5”, 48v, 110cfm fans and thermostat.
- 45”H x 26”W x 10”D Side box with removable plywood back-plate with a total of (5) 2” cable pass through openings; (4) for the primary compartment and (1) for the battery cables.
- 12” Copper ground bar on 14”risers with isolators.
- 2 panel AC load center with 50amp back-up generator plug. Interior convenience outlet and 220V supplied junction box for DC power system. See electrical layout.
- Interior lighting.
- DAC (direct air cooled) system is driven by a 10” diameter, 600 cfm, 48v fan drawing air through a 2” thick MERV 16, GR-487 Salt Fog filter.

FIGURE 1: BASIC COMPONENT BREAKDOWN FOR THE LTEE-D (above). FIGURE 2: BASIC AIRFLOW AND CLIMATE CONTROL DESCRIPTION (below).

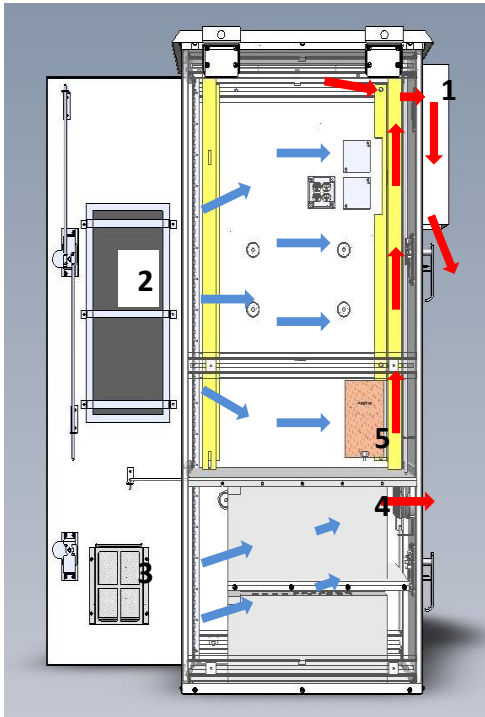

#### DAC AIRFLOW

##### (Side Cut View)

- Cold air flow will be supplied by the 600cfm fan mounted on the rear door (1). Intake of outside air will flow in through the intake shroud and through the MERV 16, GR-487 Salt Fog filter (2) and through the equipment.
- The battery compartment will be ambient air cooled via 2, 110cfm, 48v fans, drawing air through the 0.5 micron filter on the door (3) and exhausted out the top rear of the compartment (4).
- HT-300: Rail mounted 300 watt strip heater with preset thermostat. Settings are on at 45 deg F and off at 55 deg F; will assist in “cold start” situations and aid in humidity control (5).
- The refresh cycle for the top equipment compartment with 100% new air occurs every 5.5 to 6 minutes with no equipment in place. Refresh rate with equipment in place would be 4.5 to 5 minutes.

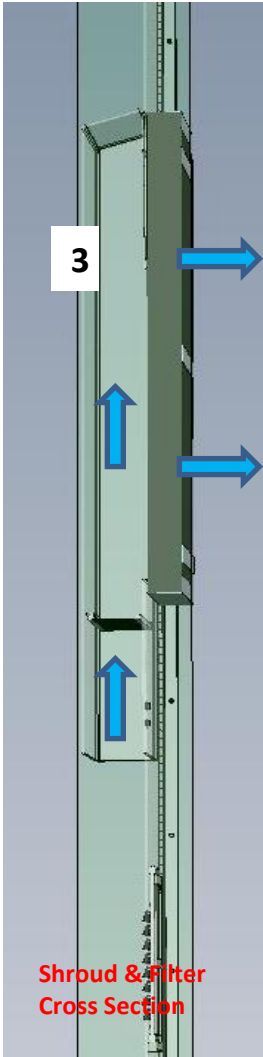

Shroud & Filter  
Cross Section

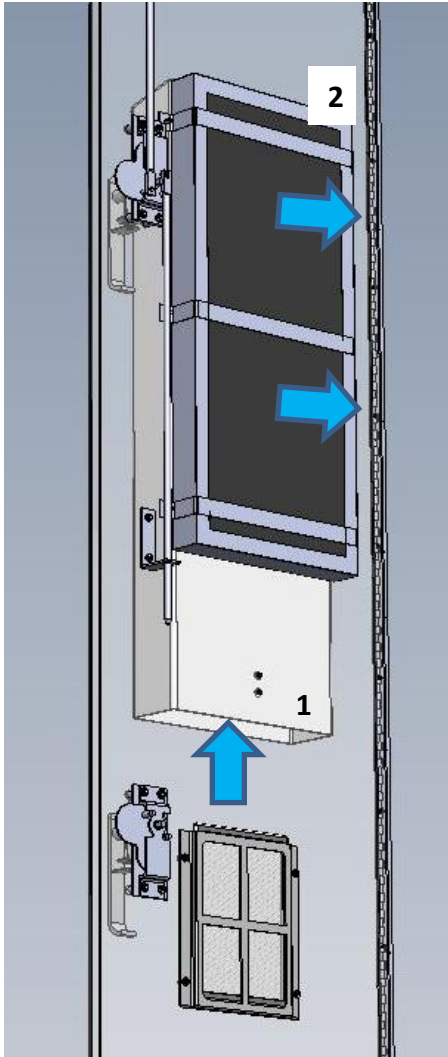

**DAC AIRFLOW CONTINUED**  
**(Front door open and door transparent)**

- Cold air flow will be supplied by the 600cfm, 48v fan mounted on the rear door.
- Intake of outside air will flow in through the intake shroud (1) and through the MERV 16, GR-487 Salt Fog filter (2) and through the equipment.
- The filter can be removed for cleaning and or replacement by removing the 3 filter straps as shown to the right.
- Cross section view of DAC airflow through the intake shroud and filter (3).

**FIGURE 3:** DIRECT AIR COOLED DESCRIPTION OF AIRFLOW THROUGH THE INTAKE SHROUD, FILTER AND INTO ENCLOSURE.

2.3.2 INTAKE FILTER DETAILS

The door mounted intake filter in the LTEE-D unit is a MERV 16 rated, GR-487 salt-fog compliant filter. The DAC (Direct Air Cooled) unit is designed to keep the equipment bay within a delta T (Temperature) of 5° to 7° F above ambient temperature.

The airflow from the intake shroud and through the door and filter opening is described below in FIGURE 4.

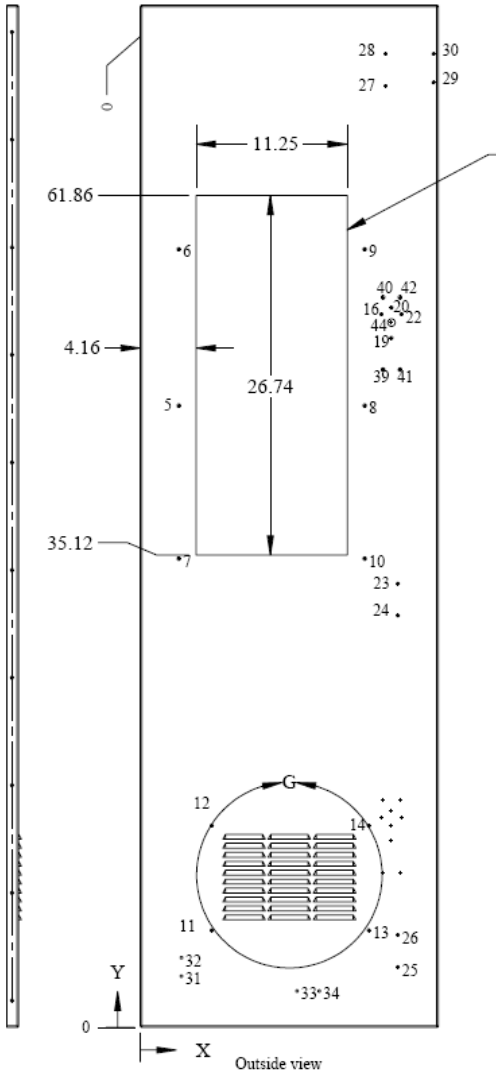

FIGURE 4: OUTSIDE VIEW OF FRONT DOOR WITH CUTOUTS FOR THE INTAKE. Cutout dimensions and hole locations are depicted in TABLE 1 on the next page.



TAG	XLOC	YLOC	SIZE	TAG	XLOC	YLOC	SIZE
1	5.45	51.52	Ø .25	30	21.83	72.38	Ø .19
2	6.6	46.91	Ø .25	31	3.06	3.81	Ø .19
3	14.1	46.91	Ø .25	32	3.06	5.19	Ø .19
4	1.95	64.27	Ø .25	33	11.67	2.71	Ø .19
5	2.86	46.23	Ø .25	34	13.33	2.71	Ø .19
6	2.86	57.86	Ø .25	35	18.07	11.5	Ø .26
7	2.86	34.86	Ø .25	36	19.33	11.5	Ø .26
8	16.7	46.23	Ø .25	37	19.33	16.88	Ø .26
9	16.7	57.86	Ø .25	38	18.07	16.88	Ø .26
10	16.7	34.86	Ø .25	39	18.07	48.9	Ø .27
11	5.32	7.22	Ø .21	40	18.07	54.28	Ø .27
12	5.32	15	Ø .21	41	19.34	48.9	Ø .27
13	17.01	7.22	Ø .21	42	19.33	54.28	Ø .27
14	17.01	15	Ø .21	43	18.7	15	Ø .56
15	17.95	15.62	Ø .22	44	18.7	52.4	Ø .56
16	17.95	53.02	Ø .22	45	6.6	33.91	Ø .28▽.03
17	18.7	13.86	Ø .22	46	14.1	33.91	Ø .28▽.03
18	18.7	16.11	Ø .22	47	12.82	62.77	Ø .25 THRU
19	18.7	51.26	Ø .22	48	4.49	59.91	Ø .27▽.02
20	18.7	53.51	Ø .22	49	5.49	52.68	Ø .27▽.02
21	19.44	15.62	Ø .22	50	10.79	59.91	Ø .27▽.02
22	19.45	53.02	Ø .22	51	15.3	52.68	Ø .27▽.02
23	19.18	33	Ø .19	52	15.99	59.91	Ø .27▽.02
24	19.18	30.63	Ø .19				
25	19.18	4.5	Ø .19				
26	19.18	6.88	Ø .19				
27	18.27	70	Ø .19				
28	18.27	72.38	Ø .19				
29	21.83	70.25	Ø .19				

TABLE 1: HOLE LOCATION TABLE FOR THE FRONT DOOR OF THE LTEE-OD.

The airflow intake area consists of 300 in<sup>2</sup>.

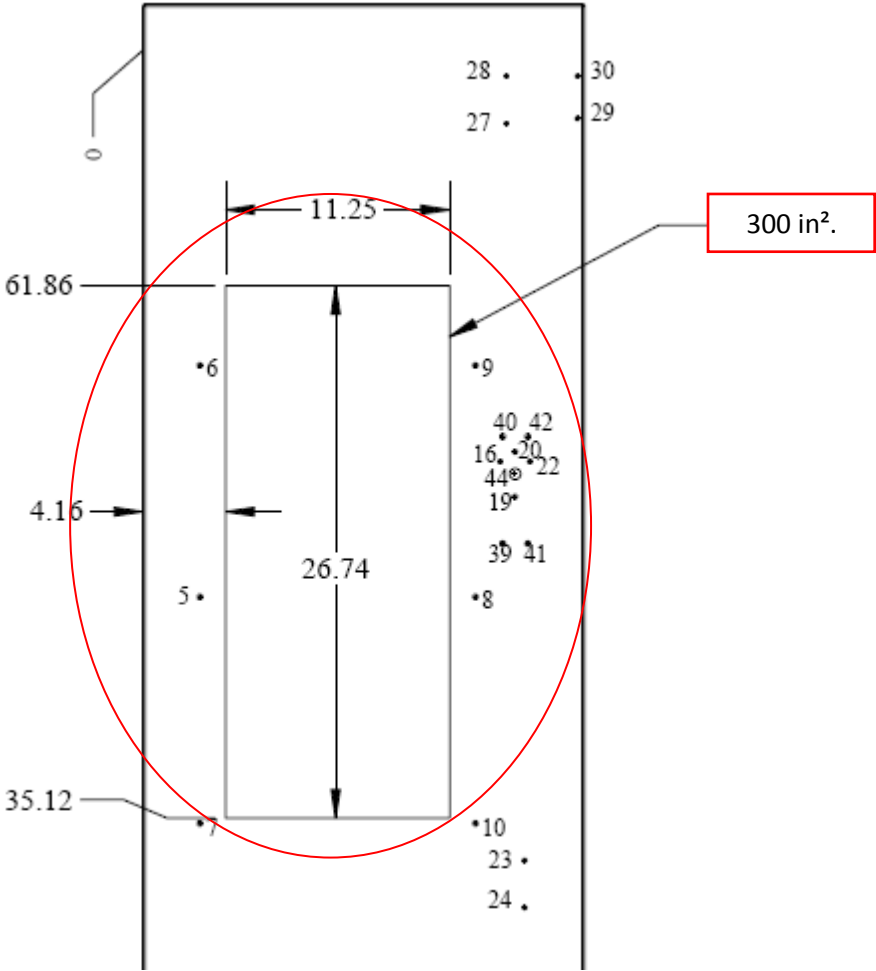

FIGURE 5: Intake cutouts on front door. View from door exterior.

**NOTE:** There is an available front and rear door kit that includes a 220v 6000 BTU programmable air conditioner with 400 watts of heat. This kit allows for a quick and simple infield upgrade to air conditioning in situations where Direct Air Cooling is insufficient or not desired due to various equipment specifications. The AC load panel will come pre-wired for this upgrade; 20amp breaker will be included in the panel as well.

Please contact DDB Unlimited, Inc. for inquiries and assistance related to this upgrade.

2.3.3 FILTER SPECIFICATIONS

Technical Data:	
<b>Construction Materials</b>	
Frame	Stainless Steel, Plastic, Aluminum, Galvanized Steel
Filter Media	Meltblown polypropylene laminated to a polyolefin non-woven support
Potting	Polyurethane
<b>Application Performance</b>	
Operating Temperature Range	-40°C to + 65°C (-40°F to +150°F)
Humidity	0 to 100 % RH
Typical Operating Airflow	100 - 550 m <sup>3</sup> /h (59-325 CFM)
Typical Initial dP	25 - 100 Pa (.10 - .40 in. wg)
Typical Final dP	200 -325 Pa (.80 - 1.3 in. wg)
Filter Efficiency 95+% [@ 0.3µm, 3.45m/sec (57 FPM)] MERV 16 ASHRAE 52.2-2007	
<b>Industry Compliance*</b>	
Water, Salt & Dust Ingress:	Telcordia GR-487 - CORE
Underwriters Laboratories:	UL 900 Standard Air Filter Units
CLC Air Standards:	Water Hold Out Test

TABLE 2: INTAKE FILTER SPECIFICATIONS

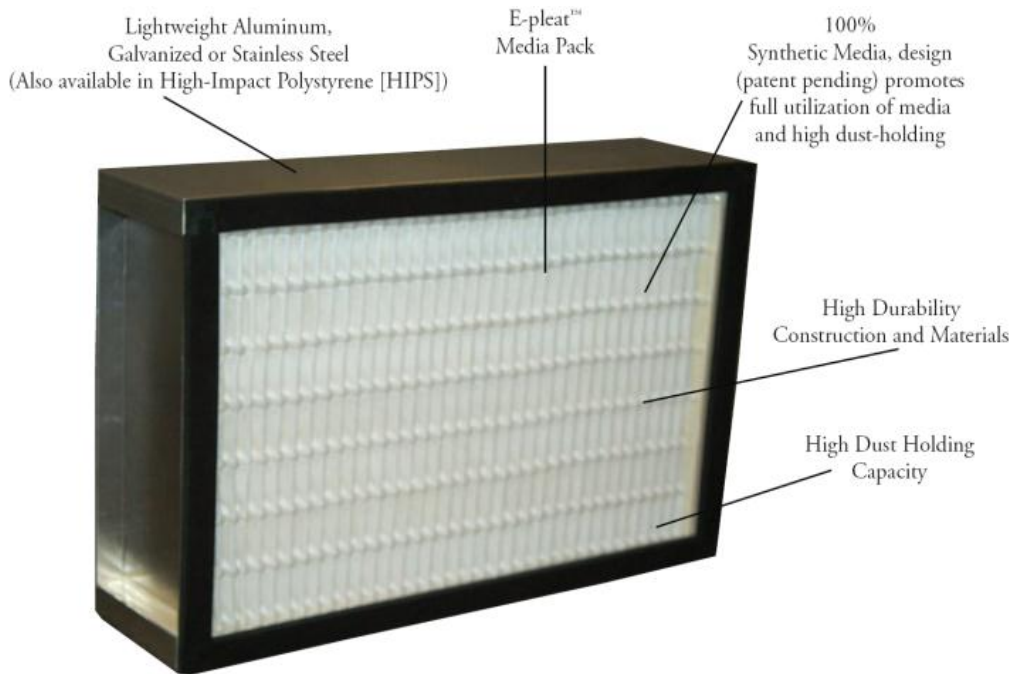
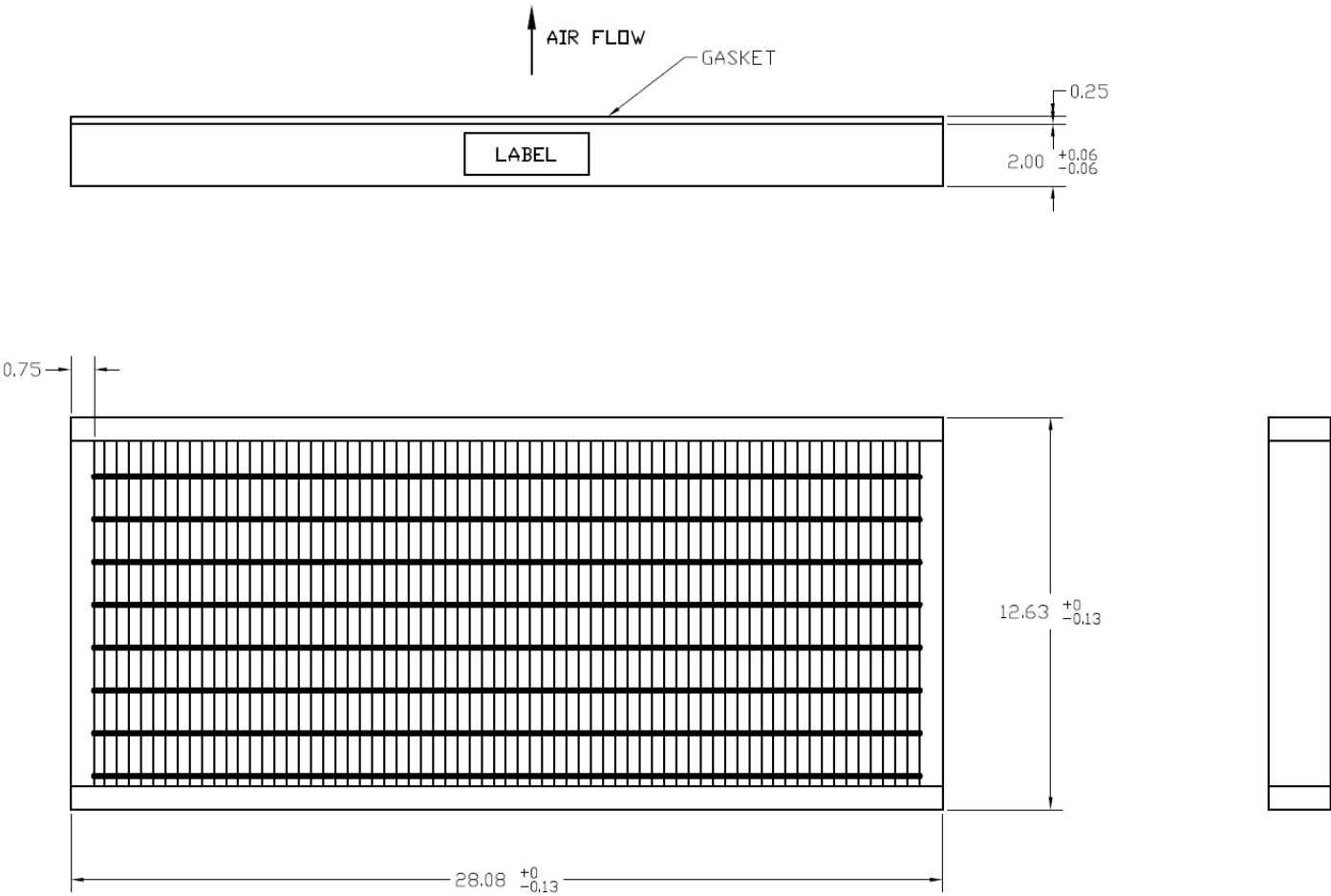

FIGURE 6: FILTER DESCRIPTION



- NOTES:
- 1. FRAME MAT'L: 16 GA ALUMINUM- C STYLE CONSTRUCTION
  - 2. MEDIA ELEMENT: E-PLEAT SYNTHETIC
  - 3. GASKET: 1/4 X 3/4 PORON - DOWNSTREAM
  - 4. SEALANT: URETHANE TOP, BOTTOM, & SIDES

FIGURE 7: FILTER SCHEMATIC DRAWING AND NOTES

2.3.4 CABINET VIEWS AND OVERALL DIMENSIONING FOR THE LTEE-D

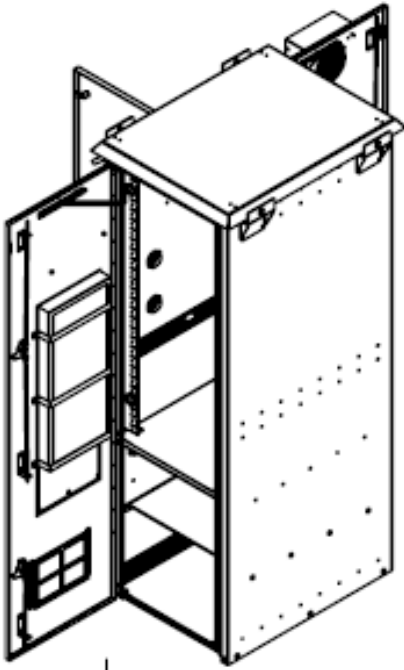

FIGURE 8: ISOMETRIC VIEW OF THE LTEE-D.

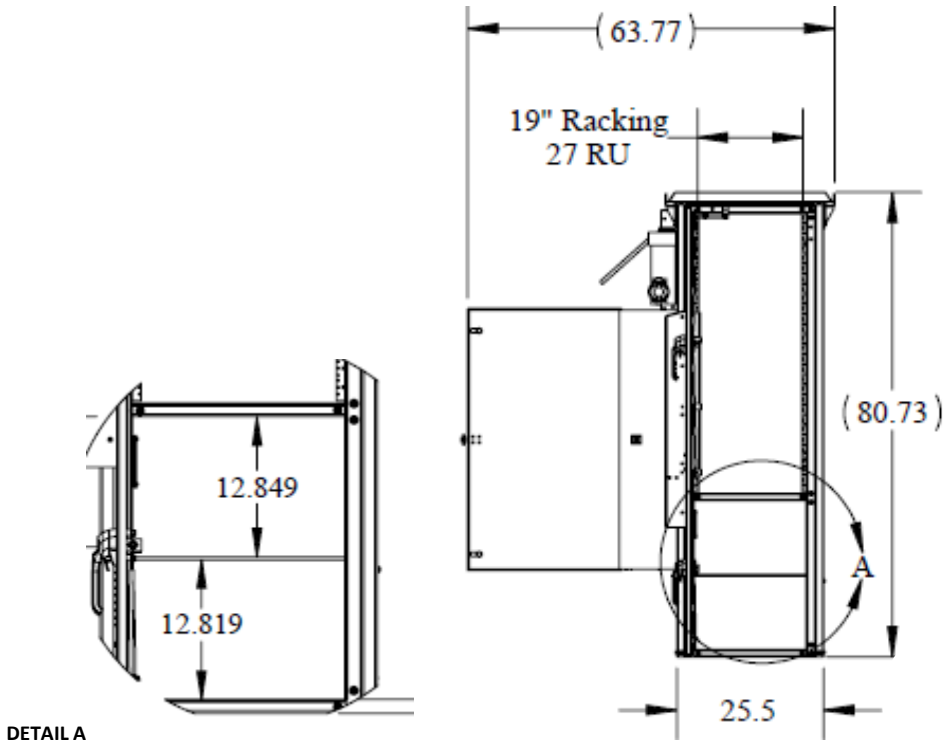
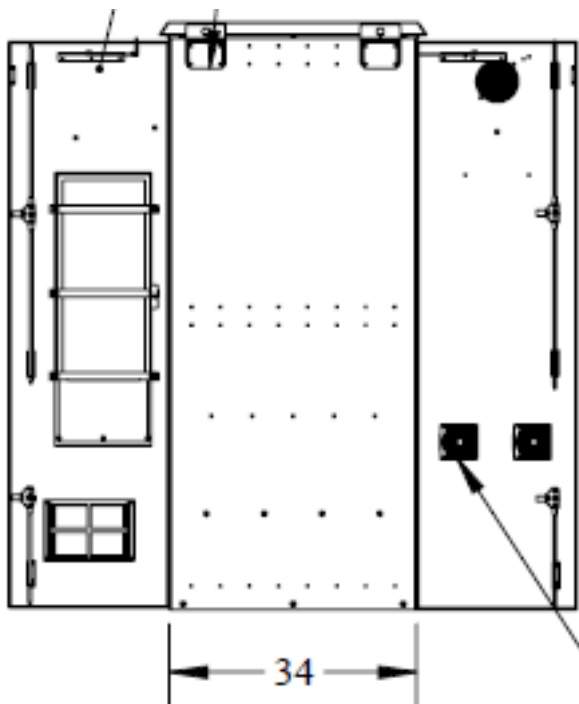

FIGURE 9: FRONT DIMENSIONAL VIEW OF THE LTEE-D.



Fan cooled Battery Compartment (NEMA 3R) using (2) 5", 48v, 110cfm fans and thermostat.

FIGURE 10: RIGHT SIDE VIEW OF THE LTEE-D

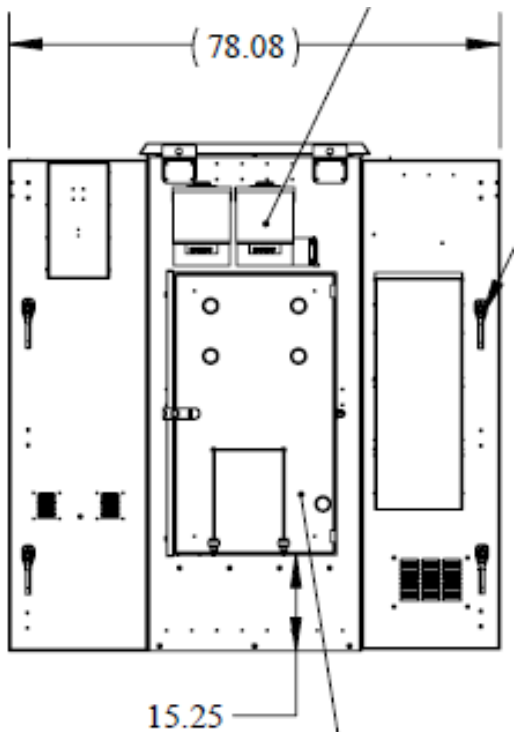

FIGURE 11: LEFT SIDE VIEW OF THE LTEE-D

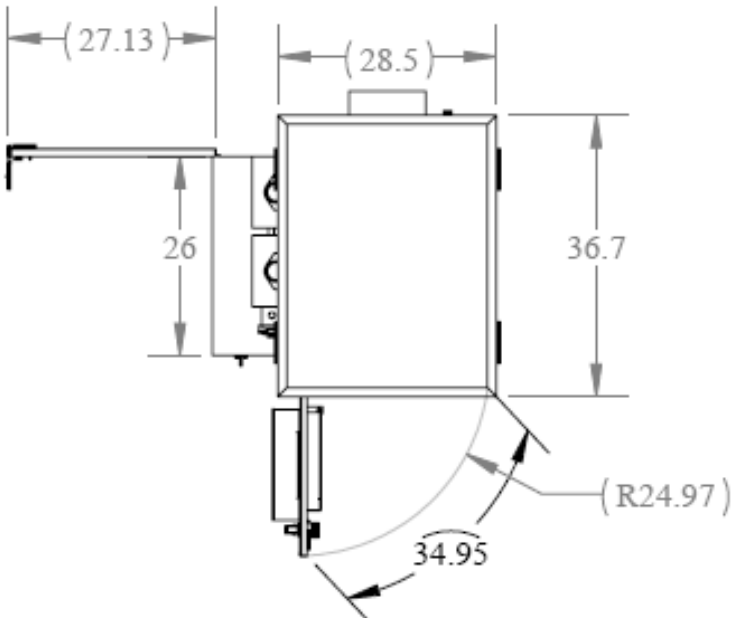

FIGURE 12: TOTAL OCCUPIED SPACE OF THE LTEE-D

2.3.5 BASE CABINET SPECIFICATIONS

A table of specifications will be added at a later time.

2.3.6 PAD MOUNTING DETAILS

PAD MOUNT LAYOUT

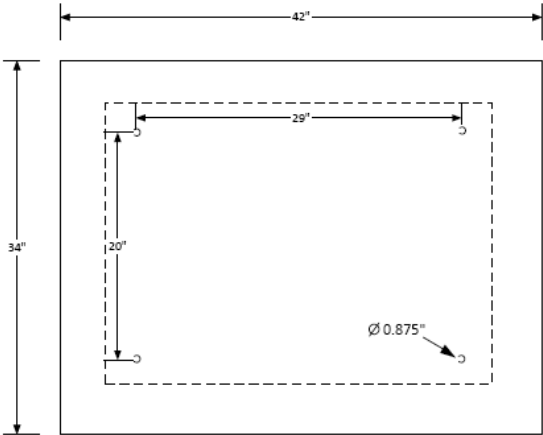

RECOMMENDED PAD LAYOUT  
42" L X 34" W, 4" THICK ¼ HARD (3000 PSI)  
CONCRETE.

NOTE: REFER TO LOCAL CODES IF ADDITIONAL ATTACHMENT IS REQUIRED.

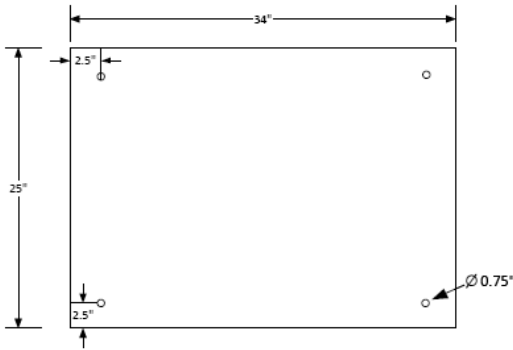

BOTTOM OF THE LTEE-D (TOP VIEW)

- RECOMMENDED PROCEDURE FOR PAD MOUNTING
1. DRILL 4 HOLES 3" DEEP, DIA 0.875" (7/8) PER DRILL PATTERN IN CONCRETE PAD. CLEAN HOLES OF DEBRIS.
  2. USING A HAMMER, LIGHTLY TAP 3" LAG SLEEVE INTO HOLE UNTIL FLUSH WITH PAD SURFACE.
  3. PLACE ENCLOSURE ON PAD WITH ALIGNMENT OF HOLES.
  4. USE 2" FENDER WASHER, LOCK WASHER AND SECURE WITH 3"x½" LAG BOLTS.

FIGURE 13: PADMOUNTING DETAIL

2.3.7 EXHAUST FAN DETAILS

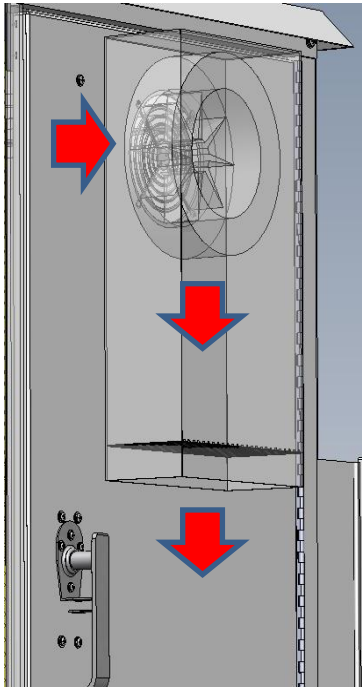

**EXHAUST FAN AIRFLOW**

- The exhaust fan shroud is mounted high on the rear door to facilitate drawing the warmest air off the top of the enclosure as it rises behind the equipment.
- The 600 cfm fan is 48v powered and controlled via thermostat. The fan is also protected by an in-line fuse.

FIGURE 14: REAR DOOR EXHAUST FAN AIRFLOW

**Characteristic Curves**

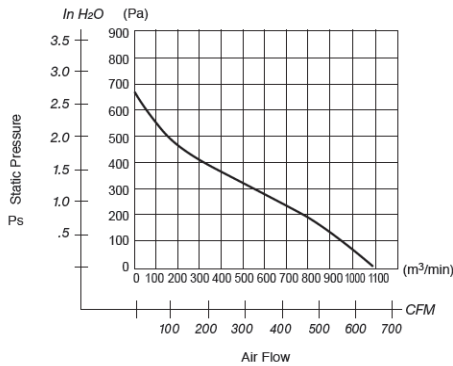

**Material**

- Impeller : Plastic
- Bearing : Ball Bearings

**Specifications**

MODEL	Product No.	Rated Voltage	Operating Voltage	Current	Input Power	Speed	Max. Air Flow		Max. Static Pressure		Noise	Mass
		(V)	(V)	(A) <sup>1</sup>	(W) <sup>1</sup>	(min <sup>-1</sup> ) <sup>1</sup>	CFM <sup>1</sup>	(m <sup>3</sup> /H)	in H <sub>2</sub> O	(Pa) <sup>1</sup>	(dB) <sup>1</sup>	(g)
225R099-DO5	AXX	24	16 ~ 28	4.3	104	2750	679.2	1154	2.6	665	68.5	-
225R099-DO7	AXX	48	36 ~ 57	1.8	89	2750	679.2	1154	2.6	665	68.5	-

FIGURE 15: FAN CURVE AND SPECIFICATIONS. NOTE: REFERENCE LINE 2 IN THE ABOVE TABLE; PN# 225R099-D07



**General Specifications**

**Motor Protection:**  
Locker Rotor, Reverse Polarity

**Insulation Resistance:**  
100M  $\Omega$  or over with a DC500V Megger

**Dielectric Withstand Voltage:** AC 700V 1s

**Allowable Ambient Temperature Range:**  
-30°C ~ +70°C (Operating)  
-40°C ~ +70°C (Storage)

**Expected Life**

**Failure Rate: 10%**  
40°C 70,000 Hours

**Outline**

Units:  $\frac{\text{inch}}{\text{mm}}$

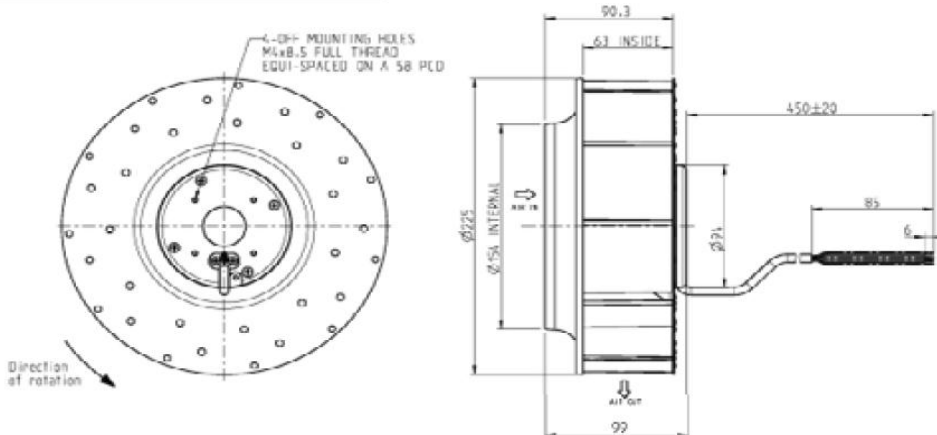

FIGURE 16: GENERAL FAN SPECIFICATIONS



INSIDE VIEW OF EXHAUST FAN WITH DOOR OPEN

# 3 ELECTRICAL & GROUNDING OVERVIEW

## 3.1 ELECTRICAL SCHEMATIC FOR THE LTEE-D & LTEE-A

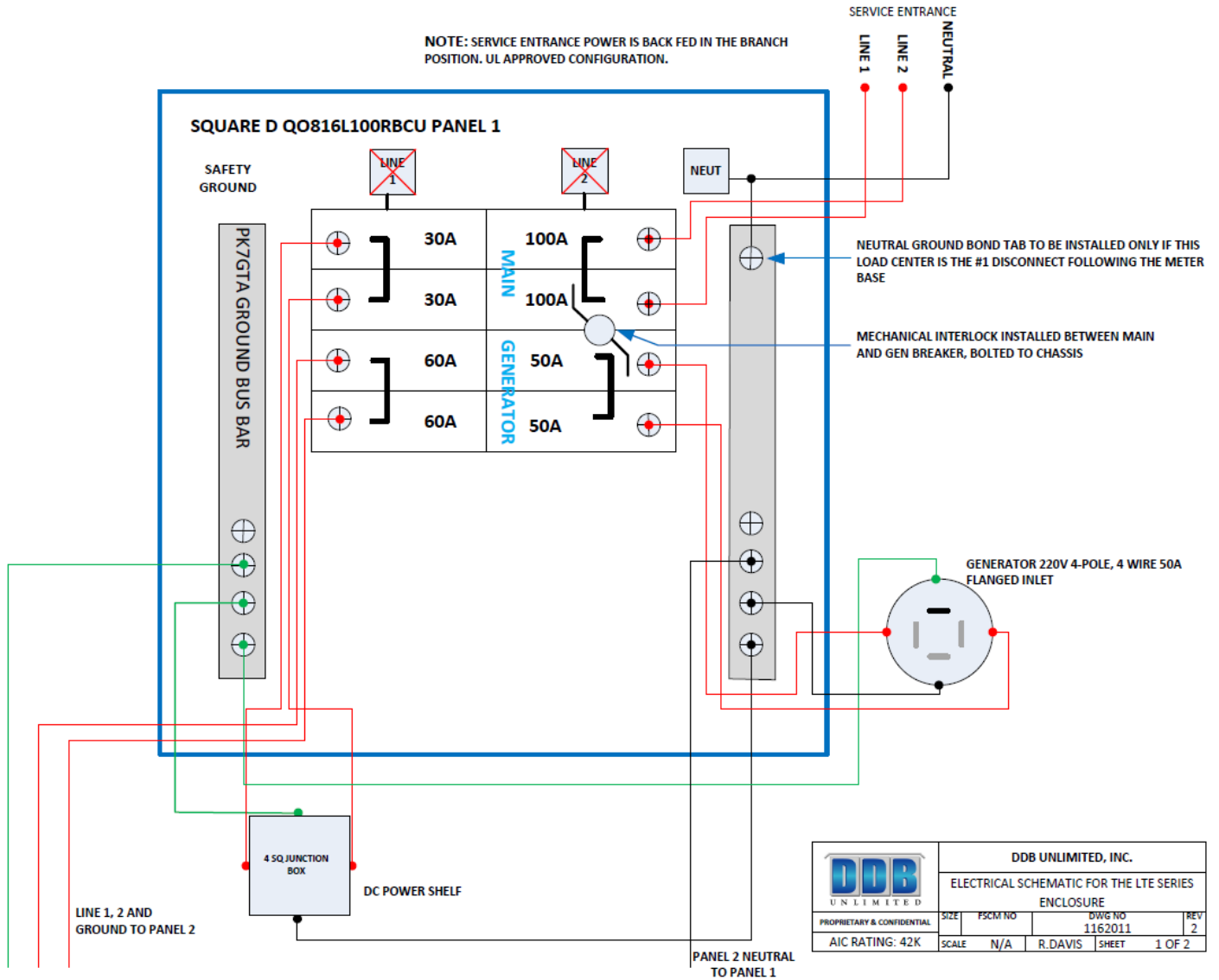
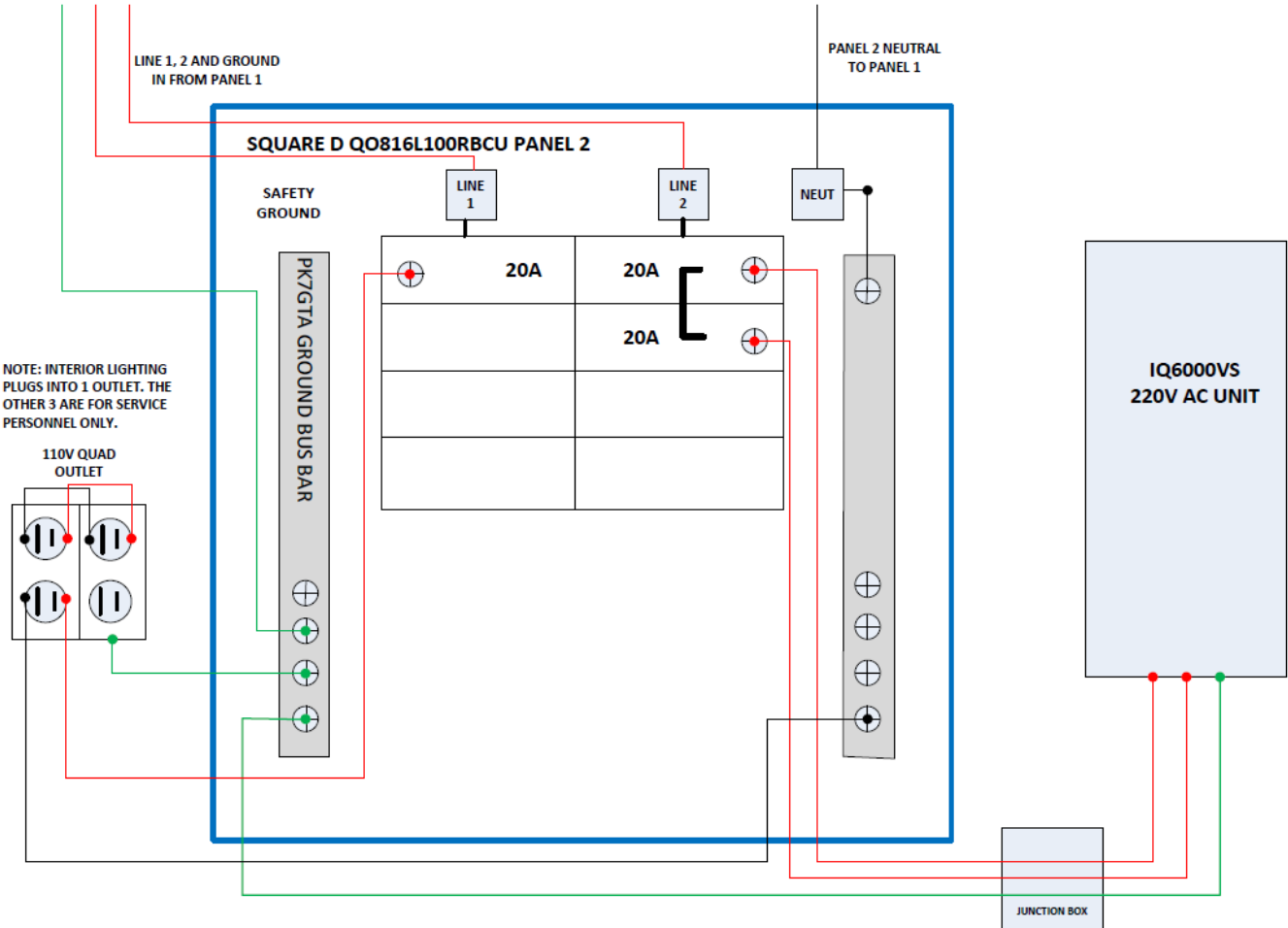

FIGURE 17: ANSI TITLE BLOCK, ELECTRICAL SCHEMATIC PG. 1



NOTE: INTERIOR LIGHTING PLUGS INTO 1 OUTLET. THE OTHER 3 ARE FOR SERVICE PERSONNEL ONLY.

		DDB UNLIMITED, INC.			
		ELECTRICAL SCHEMATIC FOR THE LTE SERIES ENCLOSURE			
PROPRIETARY & CONFIDENTIAL	SIZE	FSCM NO	DWG NO	REV	
AIC RATING: 42K	SCALE	N/A	R.DAVIS	1162011	
			SHEET	2 OF 2	

FIGURE 18: ANSI TITLE BLOCK, ELECTRICAL SCHEMATIC PG. 2

**3.2 PANEL SCHEDULE FOR THE ELECTRICAL LAYOUT**

Panel	Voltage	Designation	Wires	Mains	
Q0816L100RBCU	120/240VAC	A	3WIRE + PK7GTA	100A MLO	
Load Name	Trip	Poles	Ckt. No.	Part Number	Notes
Main	100A	2	1 2	Q0H2100	1,2
Generator	50A	2	3 4	Q0250	1,2
DC Power Shelf	30A	2	5 6	Q0230	
Feeder	60A	2	7 8	Q0260	
1. Provide Q02DTIM Interlock 2. Provide PK2MB Retainer  Manufacturer to be Square D					

Panel	Voltage	Designation	Wires	Mains	
Q0816L100RBCU	120/240VAC	B	3WIRE + PK7GTA	100A MLO	
Load Name	Trip	Poles	Ckt. No.	Part Number	Notes
AC Unit	20A	2	1 2	Q0220	
Convenience Outlet	20A	1	3 4 5 6 7 8	Q0120	
Manufacturer to be Square D					

TABLE 3: PANEL SCHEDULE FOR BOTH THE LTEE-A & LTEE-D

**NOTE:** The LTEE-D will come pre-wired with 20amp breaker installed for receiving the optional infield air conditioner upgrade.

3.3 GROUND BAR

The side box of both the LTEE-D & LTEE-A contain a 12" copper ground bar mounted on isolators. Please see the figure below.

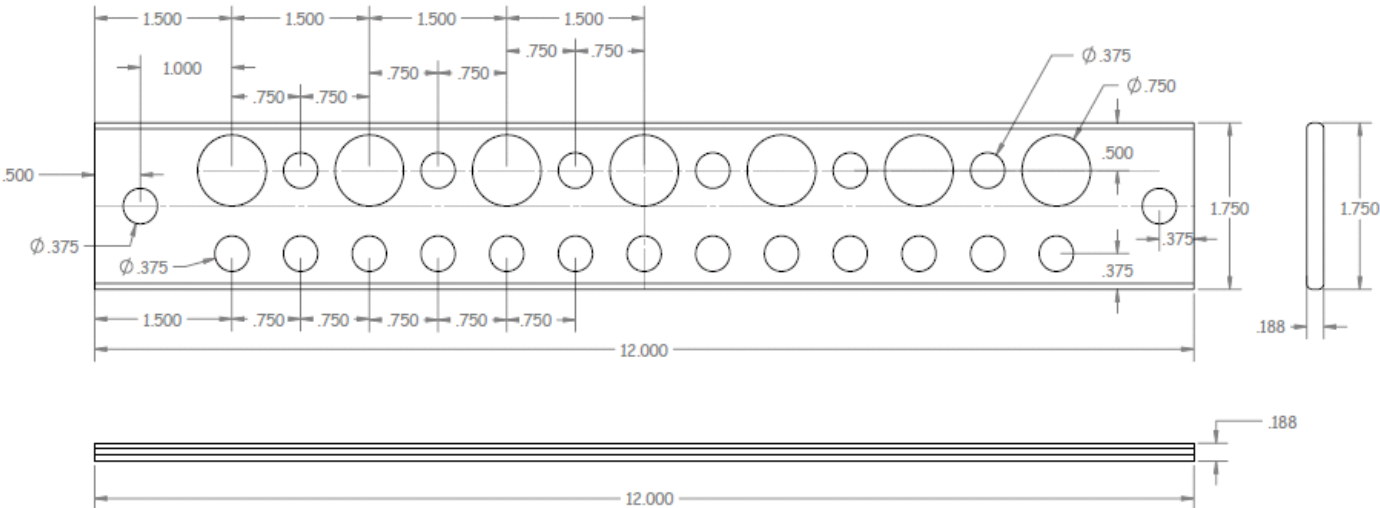

FIGURE 19: 12" GROUNDBAR



3.4 GROUND BAR ASSEMBLY DETAIL

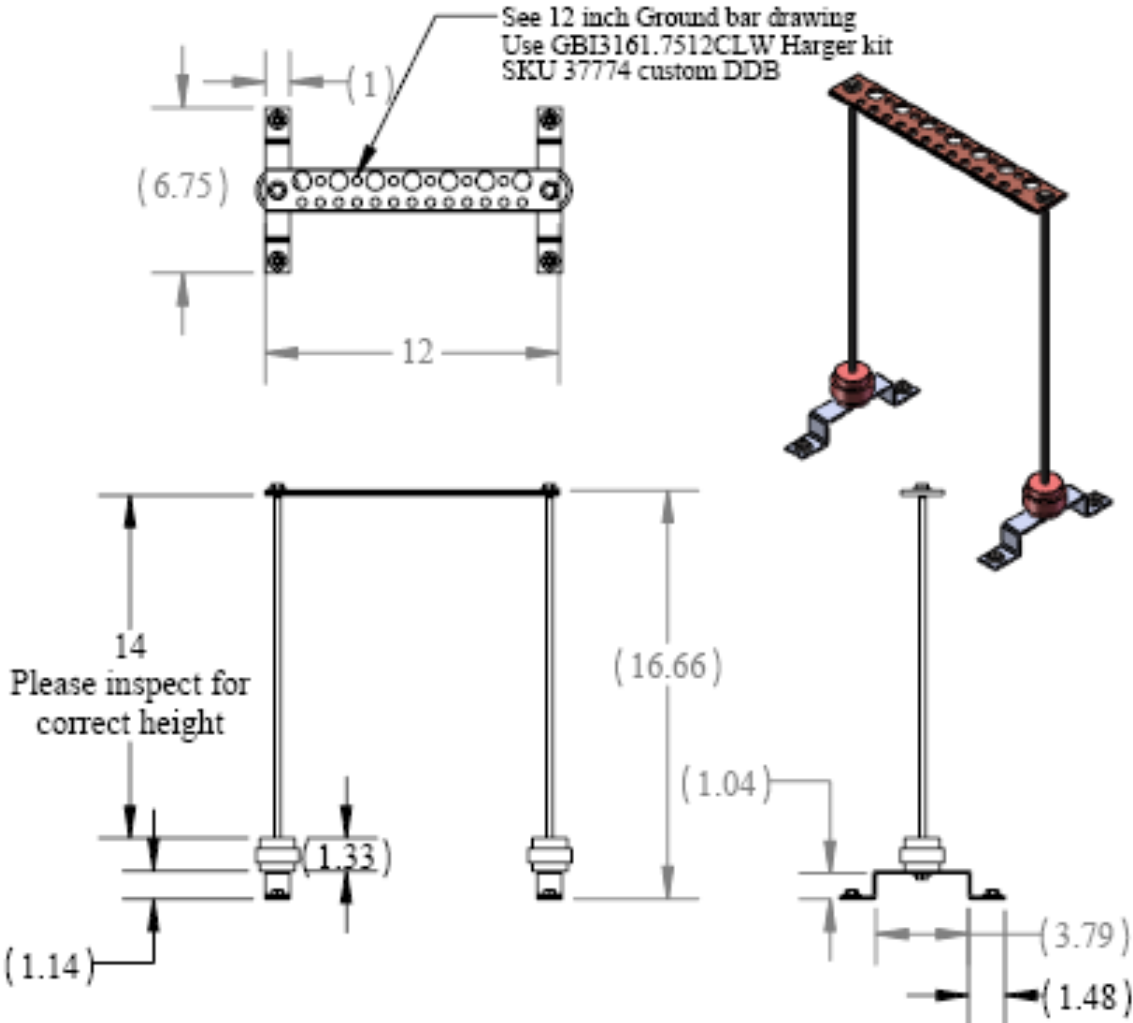

FIGURE 20: GROUND BAR ASSEMBLY DETAIL

# 4 RACK RAILS OVERVIEW

## 4.1 RACK RAILS

The rack rails for the LTE series are pictured below in Figure 34. They are made from 0.125" aluminum and have an Alodine coating. The mounting holes are tapped for a 10-32 mounting screw and are spaced according to EIA standard for 19" rack mounting.

The rack rails are etched with RU numbers for simplified installation of equipment to a prescribed mounting location. Rack rails are oriented so the RU markings are visible on the right hand rail through either the front door or the rear door; rails are adjustable front to rear to aid in equipment profile positioning.

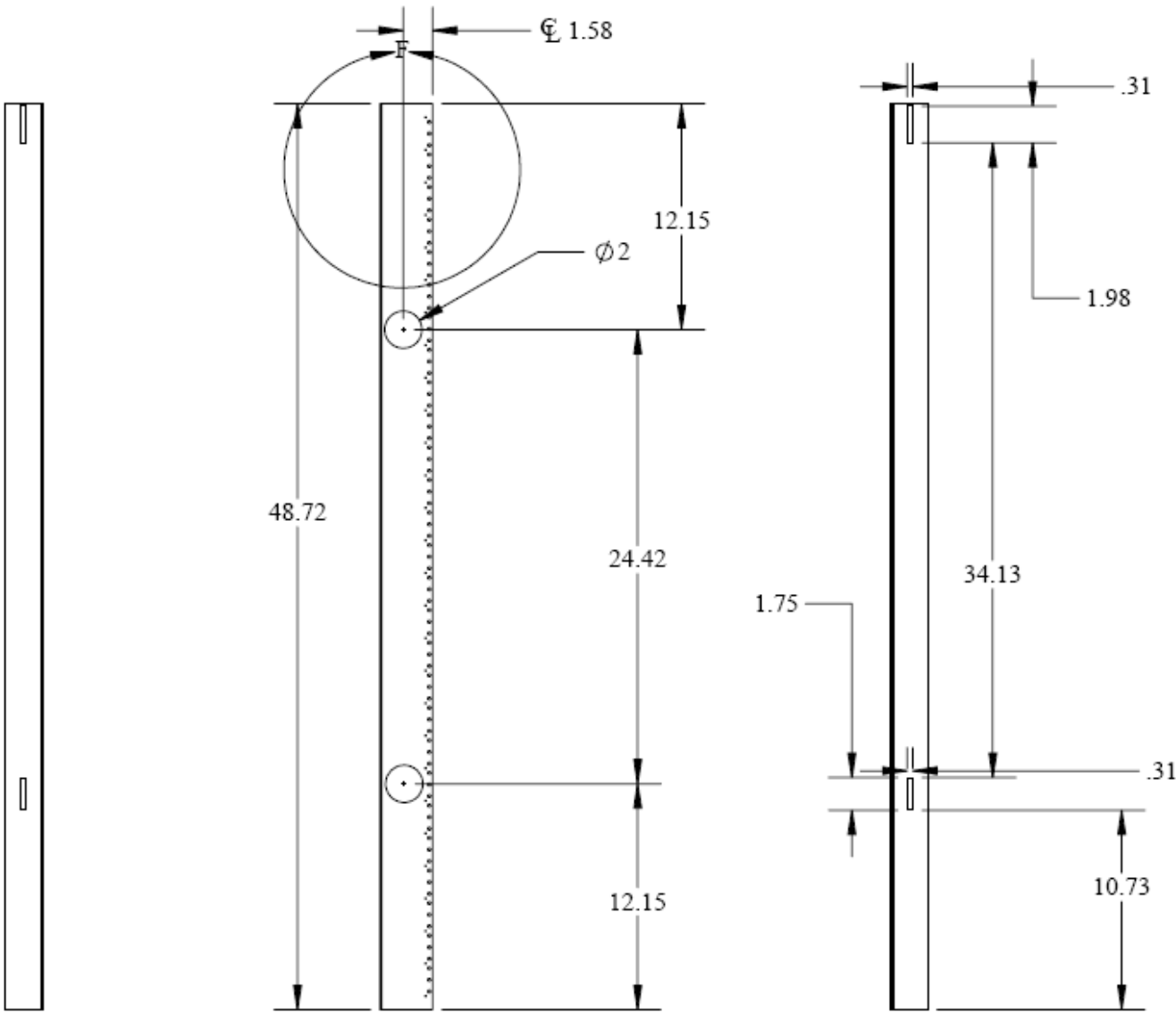

FIGURE 21: RACK RAIL DETAIL: PLEASE NOTE THAT DETAIL "F" IS ON THE FOLLOWING PAGE.

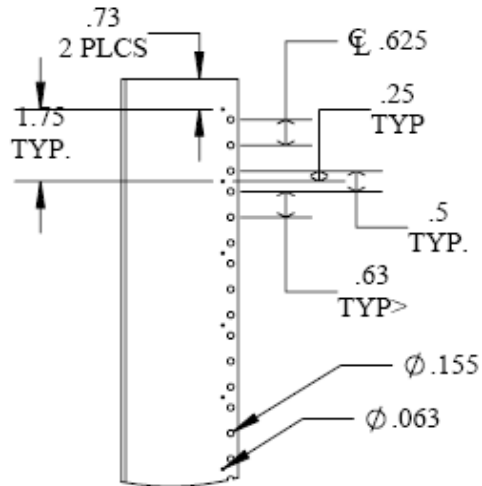

FIGURE 22: DETAIL "F" OF THE RACK RAIL DETAIL FROM THE PREVIOUS PAGE

Additionally, there is a 1/2" bridge strap that is mounted in top 1/2" of each rail for additional grounding. See notes within Figure 36.

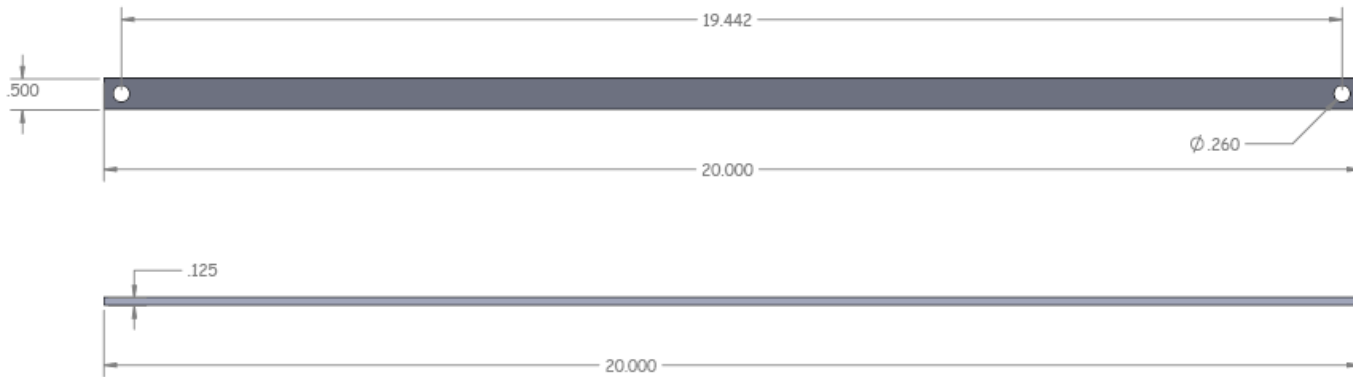
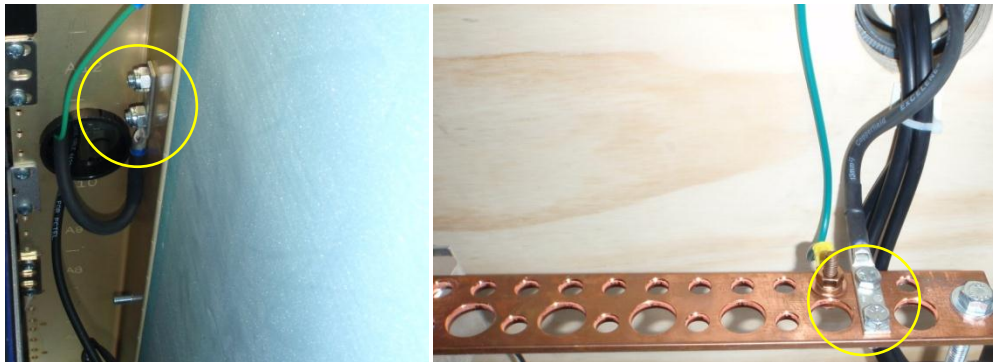

FIGURE 23: 1/2" GROUND STRAP FOR THE LTE SERIES RACK RAILS.



Double Lug rail mounted.

Double Lug ground bar mounted.



## 5 BATTERY BOX & SIDE BOX OVERVIEW

### 5.1 BATTERY BOX EXHAUST FANS



The LTE series has a direct air ventilated dual shelf battery compartment designed to hold up to strings of (4) 12v, 180ah VRLA Telecom batteries. The intake filter is mounted to the front door and the exhaust on the rear door. See FIGURE 18 for airflow detail. The battery compartment is ventilated with (2) 48v 110cfm fans. See fan detail below.

**4400 Series** Tubeaxial

119x119x38mm

- DC fans with electronically commutated external rotor motor. Fully integrated commutation electronics.
- With electronic protection against reverse polarity, locked rotor and overloading.
- Innovative impeller design with winglets.
- Fan of fiberglass reinforced plastic, PBTP housing, PBT impeller.
- Air exhaust over struts. Rotational direction CW looking at rotor.
- Electrical connection via 2 leads AWG 22, TR 64. Stripped and tinned ends.
- UL, CSA, VDE approvals on some models, please contact application engineering.

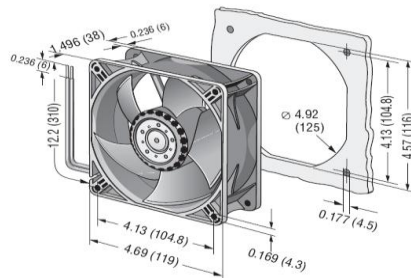

FIGURE 24: DC AXIAL EXHAUST FANS FOR THE BATTERY COMPARTMENT



## 6 APPENDICES:

### 6.1 DDB UNLIMITED WARRANTY

#### Warranty

DDB Unlimited manufactures NEMA rated weatherproof enclosures from high quality materials and warrants all enclosures for a period of (15) years from date of original purchase. This warranty covers workmanship and materials to include, but not limited to, the non-corrosive properties of the material and manufacturing defects. (WARRANTY DOES NOT COVER PRODUCTS NOT MANUFACTURED BY DDB UNLIMITED, THEY WILL HAVE THEIR OWN MANUFACTURE WARRANTY)

DDB Unlimited warrants to Customer that DDB Unlimited manufactured products sold to Customer pursuant to this Contract will be free from defects in material and workmanship, will conform to DDB Unlimited's specifications or to Customer's specifications where agreed to in writing for a period of 15 years from the date of shipment to Customer, provided that:

- A. DDB Unlimited is promptly notified (within the warranty period) of any warranty claim; and
- B. The goods and merchandise are returned to DDB Unlimited, freight prepaid, after Customer has received a return merchandise authorization number from DDB Unlimited; and
- C. DDB Unlimited's examination of such items shall disclose to its reasonable satisfaction that the claimed defect in the DDB Unlimited manufactured product was not caused by abuse, improper handling, installation, unauthorized repair, alteration or accident. Modification of DDB Unlimited manufactured product by Customer, or at Customer's direction, shall invalidate the above warranty.

DDB Unlimited's liability under this warranty is limited to repairing, replacing or issuing a credit in the amount of the unit contract price, at its election, for any such claim. Any repair or replacement shall not extend the warranty period.

Discoloration of DDB Unlimited manufactured products from metal oxidization and/or severe/normal environmental atmospheric conditions due to exposure over a period of time is normal/anticipated and is not covered by this warranty.

This warranty is extended to Customer only and is not transferable to subsequent purchasers or users of goods and merchandise. This warranty is given in lieu of all other warranties, express or implied, including implied warranties of merchantability and fitness for a particular purpose.

