



An ISO 9001  
Certified company

# OD Series

## OD-16DXC

Made in America



Believing in American  
Craftsmanship



## Why Choose the OD Series?

The OD series of enclosures are the ultimate choice for your outdoor racking requirements. Being made of our own rugged Alumiflex®, you'll find it noticeably lighter than steel, yet strong enough to rack even the heaviest equipment. When choosing the OD series, you have handpicked the highest value in American construction. The OD-16DXC includes the standard features you have come to expect with DDB, incorporating the versatile strut system for adjustable racking, the security of a 3-point locking system and our patented Alumishield® solar cap to manage heat loads. For those who need more than just our standard enclosure, DDB can also make a truly customized solution with our many available options including HVAC, providing a climate-controlled environment for any electronic equipment, electrical load panels and cable entry solutions to name a few. All of this comes together to create an enclosure able to meet all of the unique needs our customers have been seeking. DDB offers a state-of-the-art design, a competitive price, benchmark lead times and a guaranteed delivery, all backed up with an industry leading 15-year warranty on every enclosure. Put DDB's substantial stock to work for you today. Contact our professional staff to assist you with your made-to-order solution.



## Features

- 0.125" Aluminum Construction
- Stainless Steel External Hardware/Hinge
- 3 Point Lock System
- Heavy Duty Out-Door Construction
- Front and Rear Access
- Custom Colors Available
- Cream and Red Powder-Coat in Stock
- Flexible and Scalable
- 15 Year Warranty
- Quick Shipping

## Application Types

- Telecommunications
- Wireless/Broadband
- Fiber Optics
- Back Haul
- Small Cell/DAS
- Public Safety
- Utility
- Base Station
- Military
- Trailer-Based Communications
- Wi-Fi
- LTEE/4G/5G



## Industry Standards:

- NEMA 3R as shown
- NEMA 4 and 4X configurable (unlisted to environmental rating)
- OD Series Listed to UL 50/50E Type 4 Available**
- ETL listed to UL Standard 60950-1/CSA 22.2C

2301 S. HWY 77 Pauls Valley, OK 73075  
T: (800) 753-8459 – F: (877) 220-7236

[sales@ddbunlimited.com](mailto:sales@ddbunlimited.com) [www.ddbunlimited.com](http://www.ddbunlimited.com)

## Weight and Dimensions

- Approximate Exterior Enclosure Dimensions:  
18"H x 28"W x 30"D
- Shipping Dimensions:  
32"W x 42"L - Palletized
- Approximate Shipping Weight:  
98lbs.

# OD Series

## OD-16DXC

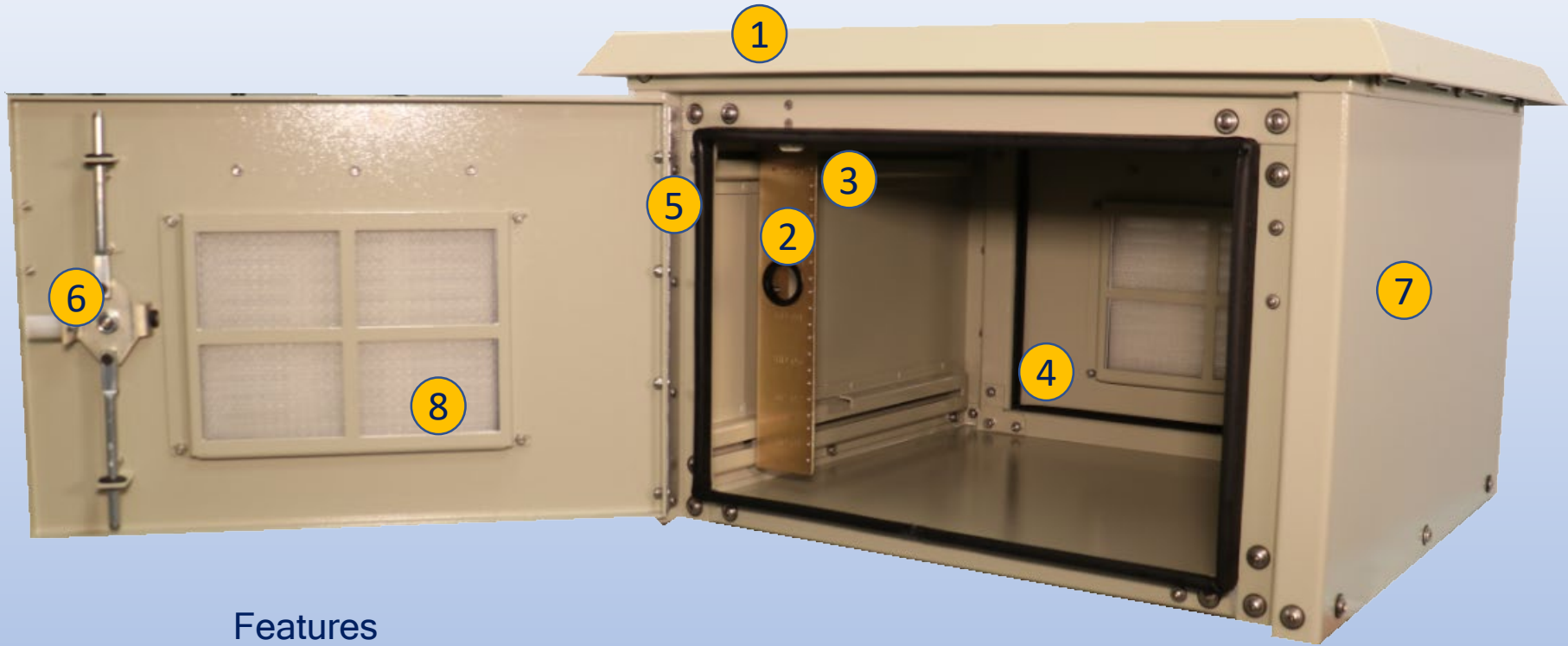

### Features

1. Solar Shield (Alumishield)
2. 19" Adjustable Racking Rails
3. 7 Racking Units
4. Rear Access Door
5. Stainless Steel Door Hinge
6. 3 Point Locking System
7. Powder-Coat Cream
8. Reusable Vent Filters

2301 S. HWY 77 Pauls Valley, OK 73075

T: (800) 753-8459 – F: (877) 220-7236

[sales@ddbunlimited.com](mailto:sales@ddbunlimited.com) [www.ddbunlimited.com](http://www.ddbunlimited.com)

**WEB DRAWING (NOT FOR FABRICATION)**

1. THIS IS A WEBSITE DRAWING. DO NOT USE FOR FABRICATION.
2. WEBSITE DRAWINGS CREATED FROM APPROVED DRAWINGS OF TOP LEVEL ASSEMBLY.

REVISIONS		
REV.	DESCRIPTION	DATE
A	Web Drawing per DR-00419	11/10/2011
B	Update DWG reflecting new components and new DWG template.	4/29/2014
C	UPDATED WITH 2019 FORMAT	2/11/2019

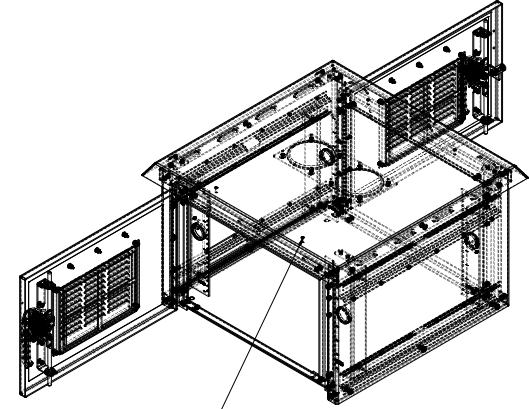
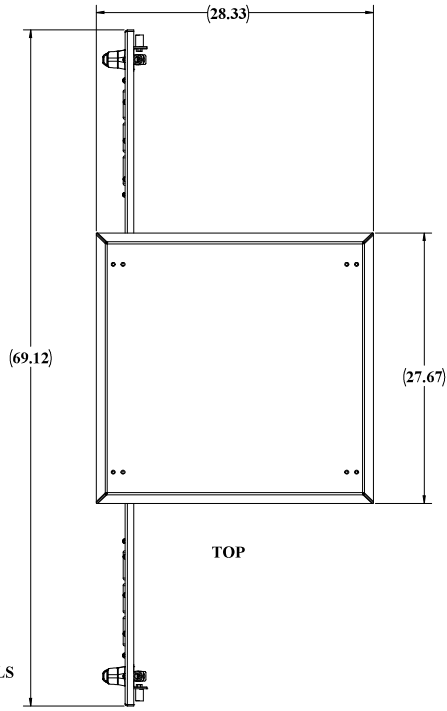

STANDOFFS STANDARD FOR OPTIONAL LIGHTING OVER EACH DOOR.

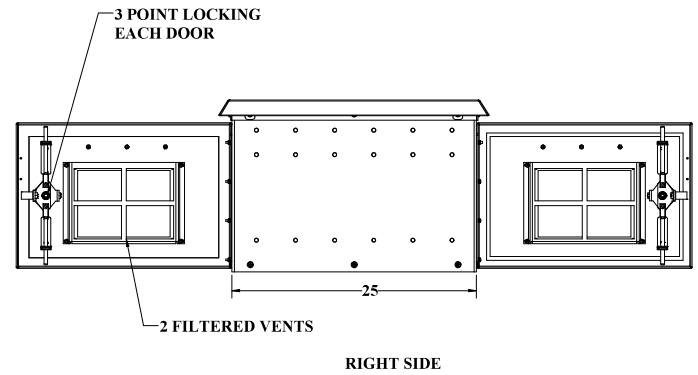
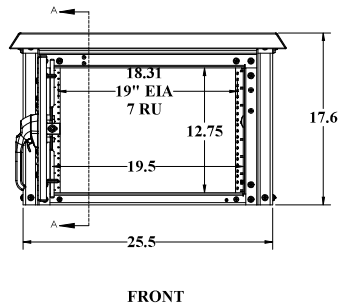
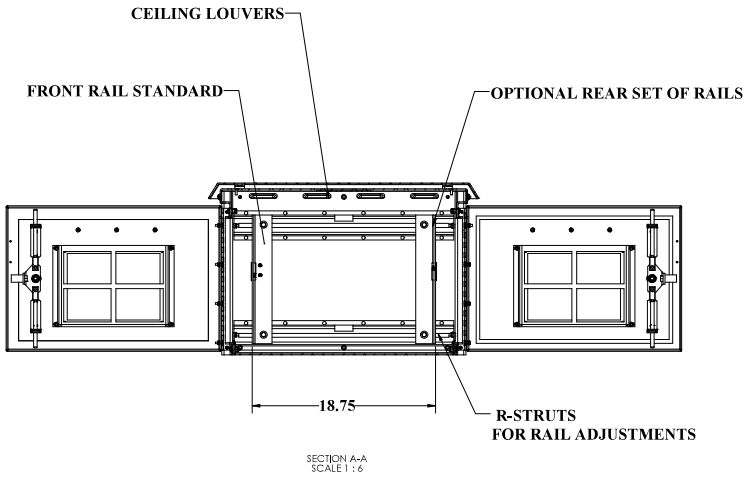

**WEB DRAWING (NOT FOR FABRICATION)**

UNLESS OTHERWISE SPECIFIED:		NAME	DATE	DDB Unlimited Inc.		
COMPONENTS ARE OF METAL	Model by:	0008	11/10/2011	OD Family Endusers		
APPLICABLE STANDARDS	Drawn by:	Manuel	02/13/19	Enclosure, OD, 16, EX		
FOR FABRICATION	Sales Rep./Rev Control/pt	14/15/11		SHE	Cage Code:	DWG. NO.:
FOR CONSTRUCTION	Q.A. Appr:	109	02/18/19	D	38515	00419
FOR FIELD INSTALLATION	Prod.Mgr.:	Clare	08/05/19			C
MATERIALS: 90% METAL, 10% POLYPROPYLENE	Created by:			SCALE: 1:32	WEIGHT: 71 lbs.	SHEET 1 OF 3
FASTENERS: 90% METAL, 10% POLYPROPYLENE						

THE INFORMATION CONTAINED IN THIS DRAWING IS THE SOLE PROPERTY OF DDB Unlimited, INC. ANY REPRODUCTION IN PART OR AS A WHOLE WITHOUT THE WRITTEN PERMISSION OF DDB Unlimited, INC. IS PROHIBITED.

DDB FORM 7.1-2 REV.F 02/11/19

WEB DRAWING (NOT FOR FABRICATION)

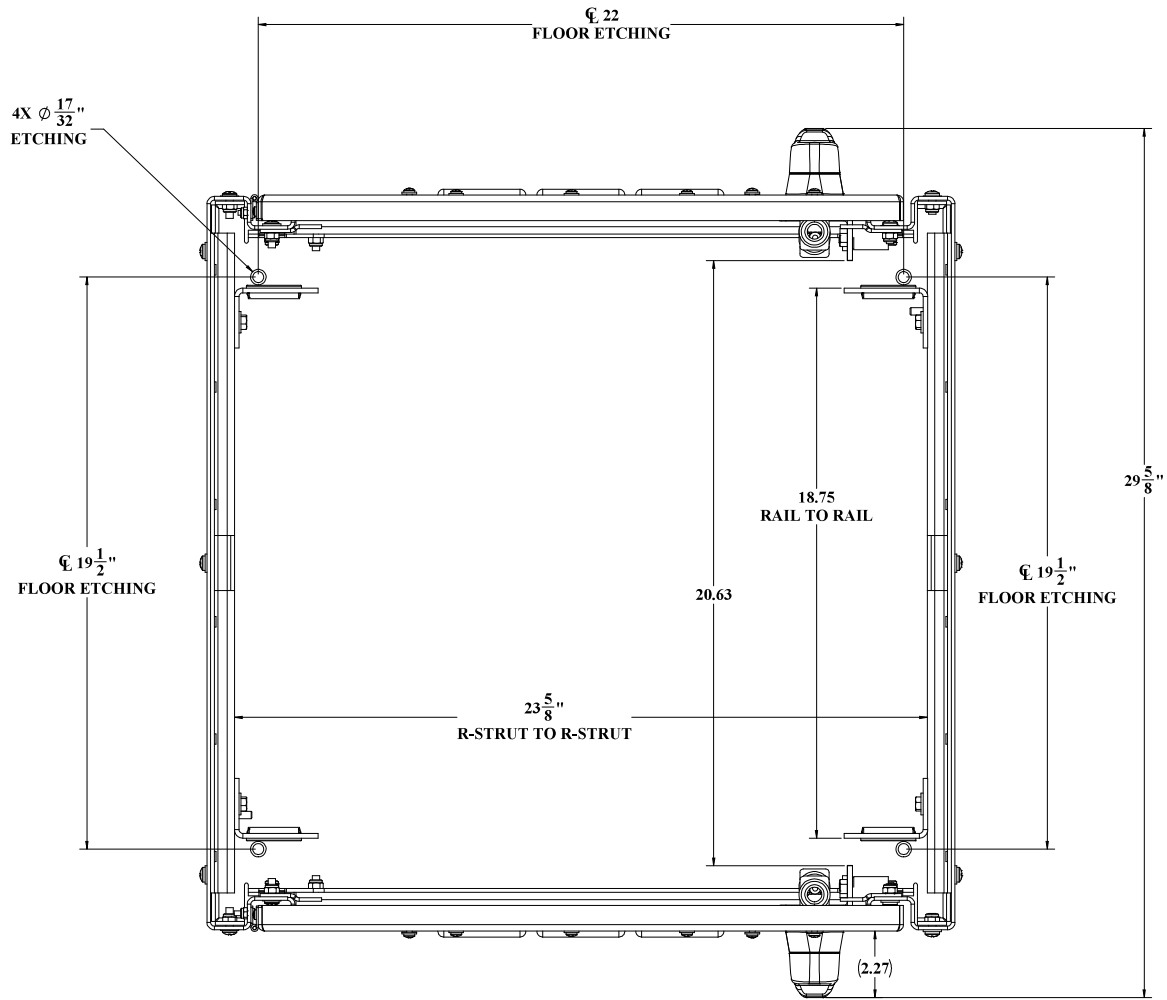

TOP VIEW CEILING AND ALUMASHIELD NOT SHOWN

WEB DRAWING (NOT FOR FABRICATION)

UNLESS OTHERWISE SPECIFIED:		NAME	DATE	<b>DDB Unlimited Inc.</b>			
CONNECTIONS ARE AS SHOWN		Model by:	0508	OD Family Enclosures			
APPLICABLE	#104	Drawn by:	Max-ws	OD Family Enclosures, EXC, Closed			
FOR USE ONLY	#105	Sales Region:	02/13/19				
THIS IS A WORKING DRAWING	#106	Q.A. Appr:	189	SHE	Cage Code:	DWG. NO.:	REV
ALL DIMENSIONS ARE IN INCHES	#107	Prod.Mgr:	Clare	D	8854	00419	C
UNLESS OTHERWISE SPECIFIED:	#108	Created by:		SCALE:	1:32	WEIGHT:	
MATERIAL: 304 STAINLESS STEEL	#109						SHEET 2 OF 3
FINISH: POLISHED	#110						
DO NOT SCALE DRAWING	#111						

THE INFORMATION CONTAINED IN THIS DRAWING IS THE SOLE PROPERTY OF DDB Unlimited, INC. ANY REPRODUCTION IN PART OR AS A WHOLE WITHOUT THE WRITTEN PERMISSION OF DDB Unlimited, INC. IS PROHIBITED.

DDB FORM 7.1-2 REV.F 02/11/19

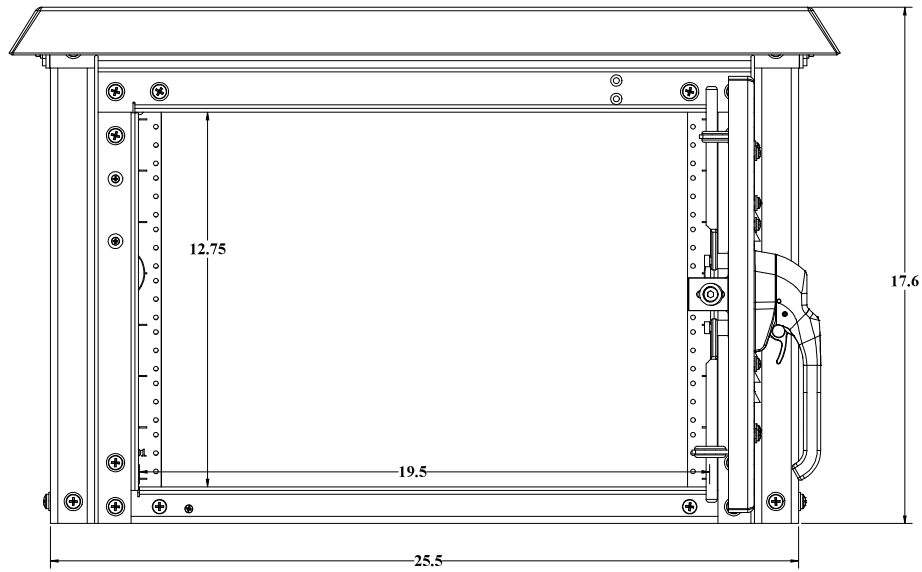

BACK VIEW GASKET NOW SHOWN

UNLESS OTHERWISE SPECIFIED:			
DIMENSIONS ARE IN INCHES			
FINISH	1"		
DRILLING	0.0005"		
DRILLING TOLERANCE	±0.0010"		
DRILLING POSITIONAL	±0.0050"		
DRILL EDGE FINISH	1.0000"		
DRILL EDGE FINISH	1.0000"		
ALL DIMENSIONS UNLESS OTHERWISE SPECIFIED			
MATERIAL: ALUMINUM 6061-T6			
PAINT: DIAMOND VOPLET, BRIDE GLASS TEXTURE			
DO NOT SCALE DRAWING			
DDB Unlimited Inc.		00419	
Facilities: OD, 16, BX			
REV	Code Code:	DWG. NO.:	REV
D	28515	00419	C
SCALE: 1:32		WEIGHT:	SHEET 2 OF 3