

OD Series

OD-30DDXC

Why Choose the OD Series?

The OD series of enclosures are the ultimate choice for your outdoor racking requirements. Being made of our own rugged Alumiflex®, you'll find it noticeably lighter than steel, yet strong enough to rack even the heaviest equipment. When choosing the OD series, you have handpicked the highest value in American construction. The OD-30DDXC includes the standard features you have come to expect with DDB, incorporating the versatile strut system for adjustable racking, the security of a 3-point locking system and our patented Alumishield® solar cap to manage heat loads. For those who need more than just our standard enclosure, DDB can also make a truly customized solution with our many available options including HVAC, providing a climate-controlled environment for any electronic equipment, electrical load panels and cable entry solutions to name a few. All of this comes together to create an enclosure able to meet all of the unique needs our customers have been seeking. DDB offers a state-of-the-art design, a competitive price, benchmark lead times and a guaranteed delivery, all backed up with an industry leading 15-year warranty on every enclosure. Put DDB's substantial stock to work for you today. Contact our professional staff to assist you with your made-to-order solution.

Application Types

- Telecommunications
- Wireless/Broadband
- Fiber Optics
- Back Haul
- Small Cell/DAS
- Public Safety
- Utility
- Base Station
- Military
- Trailer-Based Communications
- Wi-Fi
- LTEE/4G/5G



Industry Standards:

- NEMA 3R as shown
- NEMA 4 and 4X configurable (unlisted to environmental rating)
- OD Series Listed to UL 50/50E Type 4 Available**
- ETL listed to UL Standard 60950-1/CSA 22.2C

2301 S. HWY 77 Pauls Valley, OK 73075
T: (800) 753-8459 – F: (877) 220-7236

sales@ddbunlimited.com www.ddbunlimited.com



Features

- 0.125" Aluminum Construction
- Stainless Steel External Hardware/Hinge
- 3 Point Lock System
- Heavy Duty Out-Door Construction
- Front and Rear Access
- Custom Colors Available
- Cream & Red Powder-Coat in Stock
- Flexible and Scalable
- 15 Year Warranty
- Quick Shipping

Weight and Dimensions

- Approximate Exterior Enclosure Dimensions:
32"H x 28"W x 47"D
- Shipping Dimensions:
32"W x 52"L- Palletized
- Approximate Shipping Weight:
164 lbs.

OD Series

OD-30DDXC



Features

1. Solar Shield (Alumishield)
2. Front and Rear 19" Adjustable Racking Rails
3. Rear Access Door
4. Stainless Steel Door Hinge
5. 3 Point Locking System
6. Powder Coat Cream
7. Reusable Vent Filters

2301 S. HWY 77 Pauls Valley, OK 73075

T: (800) 753-8459 – F: (877) 220-7236

sales@ddbunlimited.com www.ddbunlimited.com

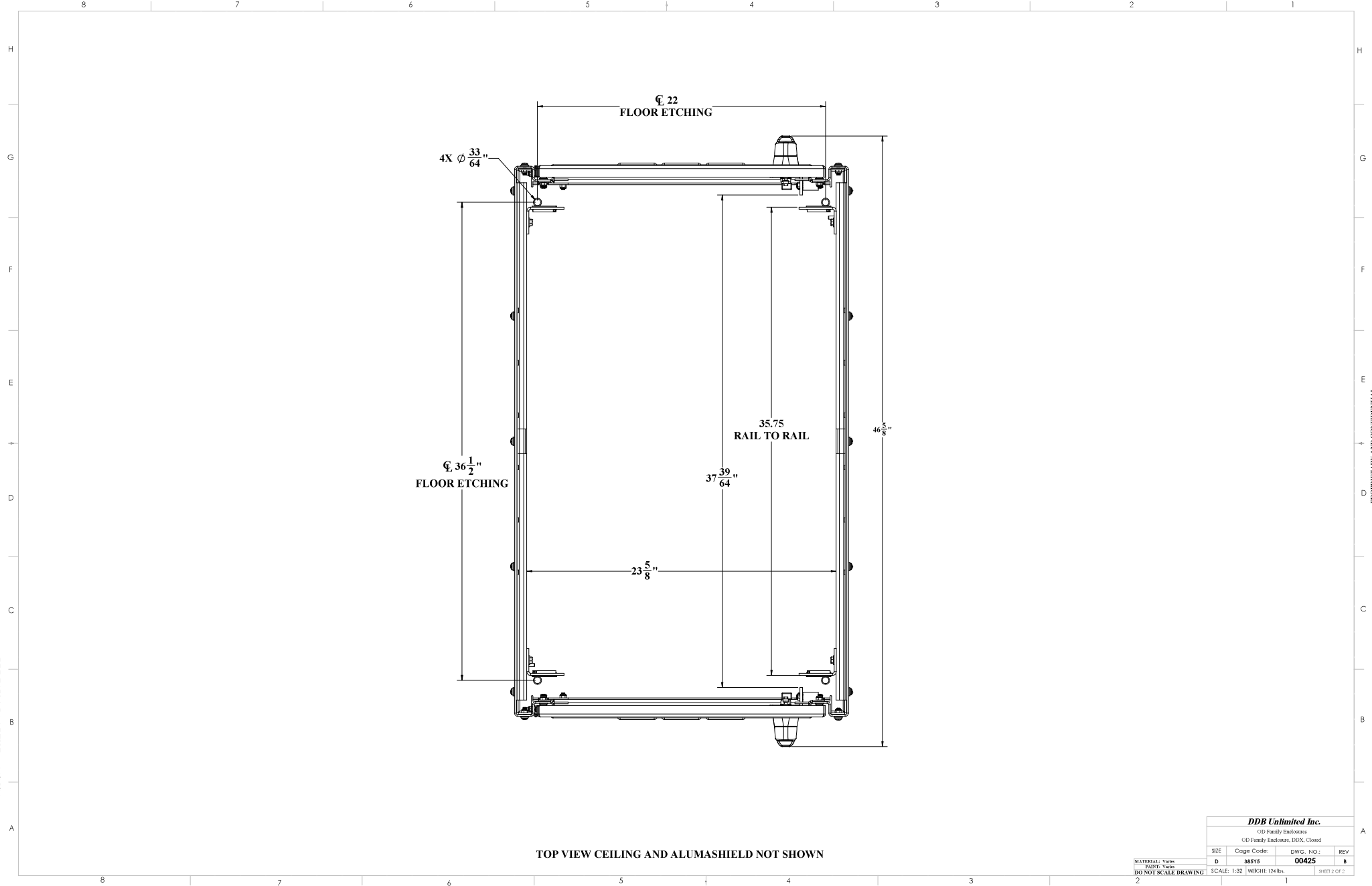

THE INFORMATION CONTAINED IN THIS DRAWING IS THE SOLE PROPERTY OF DDB Unlimited, INC. ANY REPRODUCTION IN PART OR AS A WHOLE WITHOUT THE WRITTEN PERMISSION OF DDB Unlimited, INC. IS PROHIBITED.

DDB Unlimited Inc.			
OD Family Enclosures			
OD Family Enclosure, DDX, Closed			
S/E	Cage Code:	DWG. NO.:	REV
D	88515	00425	B

MATERIAL: Vaple	SCALE: 1:32	WEIGHT: 124 lbs.	SHEET 2 OF 2
DATE: Vaple	DO NOT SCALE DRAWING		

DDB FORM 7.1-2 REV. 04/25/14