

SOD Series

SOD-302420



Why Choose the SOD Series?

The SOD series enclosure is the ultimate choice for your outdoor equipment racking applications when versatility is needed. Being constructed of our Alumiflex® material, you'll find it noticeably lighter than steel, yet strong enough to rack even the heaviest equipment. When choosing the SOD series, ease of installation along with pad, pole and wall mounting options provide endless possibilities for where you can locate. With many standard features including 3-point pad locking system, venting system with reusable filter and top solar shield; you will see the value quickly add up. Add to this a long list of available options including HVAC climate controls, electrical and cable entry solutions allows the SOD series to provide a flexibility of options that are second to none. DDB offers a state-of-the-art design, a competitive price, benchmark lead times and a guaranteed delivery, all backed up with an industry leading 15-year warranty on every enclosure. Put DDB's substantial stock to work for you today. Contact our professional staff to assist you with your made-to-order solution.



Features

- 0.125" Aluminum Construction
- Stainless Steel External Hardware/Hinge
- Heavy Duty Out-Door Construction
- Pad/Wall/Pole Mountable
- Front Door Access
- Custom Colors Available
- Cream & Red Powder-Coat in Stock
- Flexible and Scalable
- 15 Year Warranty
- Quick Shipping

Application Types

- Telecommunications
- Wireless/Broadband
- Fiber Optics
- Back Haul
- Small Cell/DAS
- Utility
- Base Station
- Military
- Trailer-Based Communications
- Wi-Fi
- LTEE/4G/5G



Industry Standards:

NEMA 3R as shown; NEMA 4 and 4X configurable (unlisted to environmental rating)

SOD Series Listed to UL 50/50E Type 4 and 3R Available

2301 S. HWY 77 Pauls Valley, OK 73075

T: (800) 753-8459 – F: (877) 220-7236

sales@ddbunlimited.com www.ddbunlimited.com

Weight and Dimensions

Approximate Exterior Enclosure Dimensions:

32"H x 24"W x 24"D

Shipping Dimensions:

32"W x 32"L - Palletized

Approximate Shipping Weight:

79 lbs.

SOD Series

SOD-302420



Features

1. Solar Shield (Alumishield)
2. 19" Racking Rails
3. Stainless Steel Door Hinge
4. Powder-Coat Cream
5. Reusable Vent Filter
6. 1/2" Conduit Knockouts

2301 S. HWY 77 Pauls Valley, OK 73075

T: (800) 753-8459 – F: (877) 220-7236

sales@ddbunlimited.com www.ddbunlimited.com

REVISIONS		
REV.	DESCRIPTION	DATE
A	WEB DRAWING PER DR-01382	4/26/16

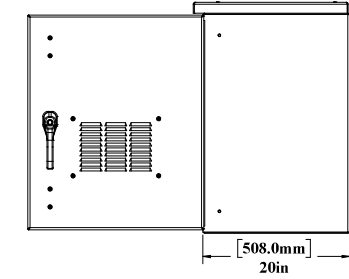
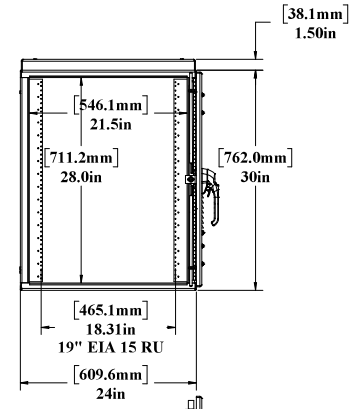
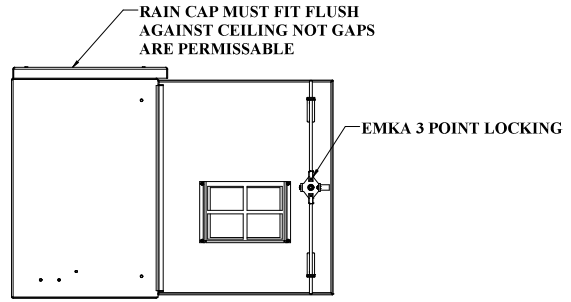
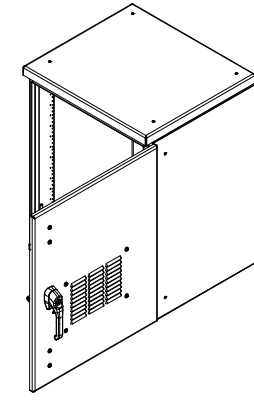
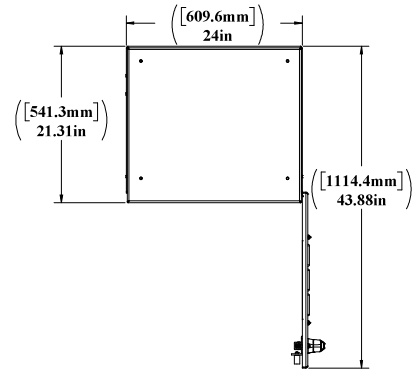

ETCHING FOR OPTIONAL MOUNTING FEET

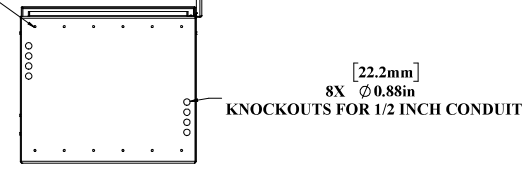

GENERAL INFORMATION SPECIFIED:			
DESIGNER	DATE	PROJECT	NO.
DRAWN	DATE	PROJECT	NO.
CHECKED	DATE	PROJECT	NO.
APPROVED	DATE	PROJECT	NO.
SCALE: 1:8			
DO NOT SCALE DRAWING			

DDB Unlimited Inc.			
SQC-302420			
SHEET	Code Code:	DWG. NO.:	REV.
D	38515	01382	A
SCALE: 1:8		WEIGHT 99 lbs.	SHEET 1 OF 2

DDB FORM 7-12 REV A 12/08/15

ALL INFORMATION CONTAINED IN THIS DRAWING IS THE SOLE PROPERTY OF DDB Unlimited, INC. ANY REPRODUCTION IN PART OR AS A WHOLE WITHOUT THE WRITTEN PERMISSION OF DDB Unlimited, INC. IS PROHIBITED.

8 7 6 5 4 3 2 1

H
G
F
E
D
C
B
A

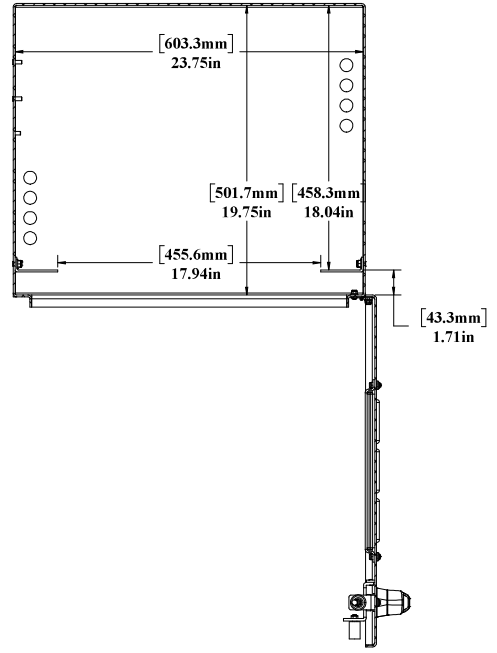
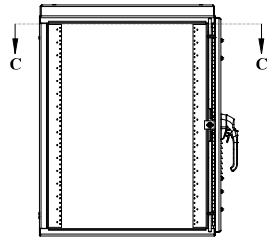

SECTION C-C
SCALE 1 : 4

GENERAL NOTES: 1. ALL DIMENSIONS ARE IN MILLIMETERS UNLESS OTHERWISE SPECIFIED. 2. DIMENSIONS ARE TO FACE UNLESS OTHERWISE SPECIFIED. 3. DIMENSIONS ARE TO CENTERLINE UNLESS OTHERWISE SPECIFIED. 4. DIMENSIONS ARE TO CENTERLINE UNLESS OTHERWISE SPECIFIED. 5. DIMENSIONS ARE TO CENTERLINE UNLESS OTHERWISE SPECIFIED. 6. DIMENSIONS ARE TO CENTERLINE UNLESS OTHERWISE SPECIFIED. 7. DIMENSIONS ARE TO CENTERLINE UNLESS OTHERWISE SPECIFIED. 8. DIMENSIONS ARE TO CENTERLINE UNLESS OTHERWISE SPECIFIED. 9. DIMENSIONS ARE TO CENTERLINE UNLESS OTHERWISE SPECIFIED. 10. DIMENSIONS ARE TO CENTERLINE UNLESS OTHERWISE SPECIFIED.			
DDB Unlimited Inc. SOC-302420			
REV	Code Code:	DWG. NO.:	REV
D	38515	01382	A
SCALE 1:8		WBHT:	SHEET 2 OF 2

THE INFORMATION CONTAINED IN THIS DRAWING IS THE SOLE PROPERTY OF DDB Unlimited, INC. ANY REPRODUCTION IN PART OR AS A WHOLE WITHOUT THE WRITTEN PERMISSION OF DDB Unlimited, INC. IS PROHIBITED.