

SVP Series

SVP-302410

Why Choose the SVP Series?

The SVP series, outdoor enclosure, is the ultimate choice for your indoor/outdoor requirements. Being made of our own rugged Alumiflex®, you'll find it noticeably lighter than steel, yet strong enough to support even the heaviest equipment. When choosing the SVP series, you are selecting the highest value in American construction. It is ideal for both indoor and outdoor applications. Due to the flexible platform, the SVP can be utilized as an electrical panel, battery storage, or communication cabinet as well as other numerous applications. The SVP series includes standard features you have come to expect, including a standard back plate, pad locking hasps, and various mounting bracket types. Additional optional accessories that can be added to enhance functionality include climate controls, venting options, and electrical/cable entry solutions. All of this comes together to create an enclosure able to meet all of the unique needs your customers have been seeking. DDB offers a state-of-the-art design, a competitive price, benchmark lead times and a guaranteed delivery, all backed up with an industry leading 15-year warranty on every enclosure. Put DDB's substantial stock to work for you today. Contact our professional staff to assist you with your made-to-order solution.



Features

- 0.125" Aluminum Construction
- Stainless Steel External Hardware/Hinge
- Heavy Duty Out-Door Construction
- Aluminum Removeable Back-Plate
- Custom Colors Available
- Cream Powder-Coat in Stock
- Flexible and Scalable
- 15 Year Warranty
- Quick Shipping

Application Types

- Telecommunications
- Wireless/Broadband
- Fiber Optics
- Back Haul
- Small Cell/DAS
- Public Safety
- Utility
- Military
- Trailer-Based Communications
- Wi-Fi
- Video/Monitoring
- Oil/Gas
- Control Panels



Industry Standards: NEMA 3R as shown

2301 S. HWY 77 Pauls Valley, OK 73075
T: (800) 753-8459 – F: (877) 220-7236
sales@ddbunlimited.com www.ddbunlimited.com

Weight and Dimensions

- Approximate Exterior Enclosure Dimensions:
31"H x 25"W x 11"D
- Shipping Dimensions:
32" x 42" - Palletized
- Approximate Shipping Weight:
75 lbs.

SVP Series

SVP-302410



Features

1. Pad Locking Hasps
2. Removable Backplate
3. Reusable Filter
4. Powder-Coat Cream

2301 S. HWY 77 Pauls Valley, OK 73075

T: (800) 753-8459 – F: (877) 220-7236

sales@ddbunlimited.com www.ddbunlimited.com

REVISIONS		
REV.	DESCRIPTION	DATE
A	CREATED WEBST DRAWING.	12/19/2014
B	UPDATED WEB DWG PER DR-01395	5/13/16

WEB DRAWING (NOT FOR FABRICATION)

For Fabrication Drawing of this enclosure see DWG #:00682

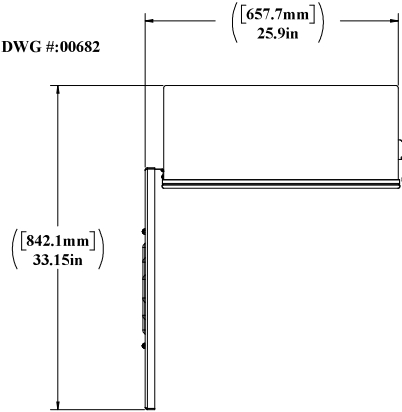

FANS OPTIONAL

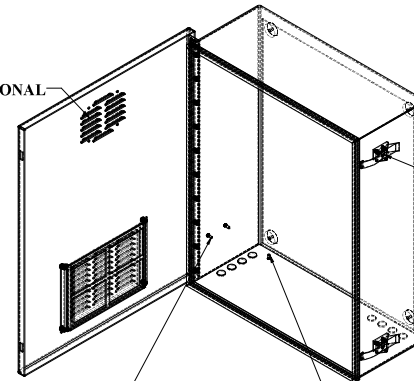

FOUR SQUARE OPTIONAL

GROUNDING STUD

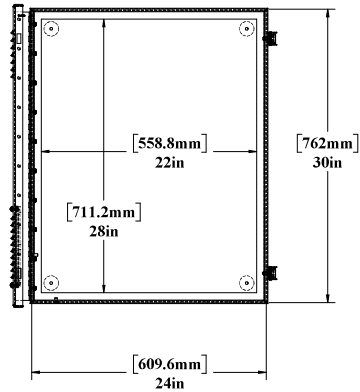

FILTERED LOUVERS

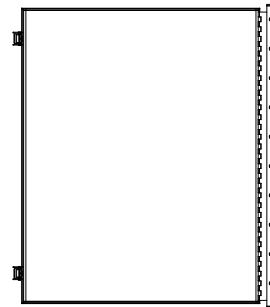
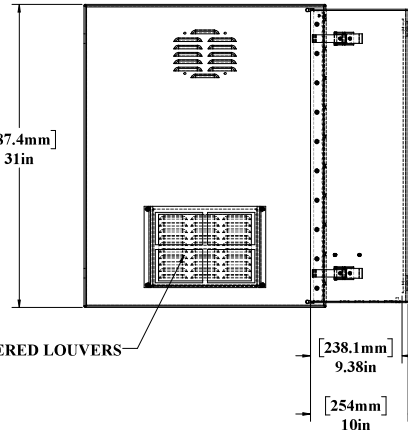

Mounting Options
AVAILABLE SEE
DWG# 00999

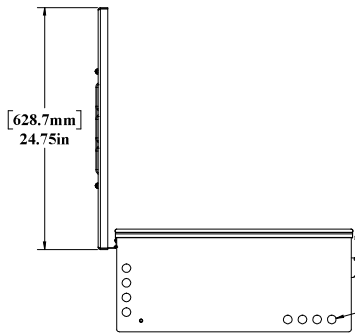

8X \varnothing .88in
KNOCKOUTS

NOTES: UNLESS OTHERWISE SPECIFIED

- DIMENSIONS AND TOLERANCES ARE IN ACCORDANCE WITH ASME Y14.5M
- DIMENSIONS ARE IN INCHES, UNLESS OTHERWISE SPECIFIED
- THIS IS A SUPPLEMENTAL DRAWING AND MAY NOT BE FULLY DIMENSIONED. THE NOTES, TOLERANCES, AND SPECIAL INSTRUCTIONS ARE TO BE USED ALONG WITH THE LATEST REVISION OF THE SOLID DATABASE. THE PART OR ASSEMBLY IS TO BE CONTROLLED PER THE ELECTRONIC FILE
- ALL PEM STUDS SHALL BE PHS FOR STAINLESS ENCLOSURES AND PHA FOR ALUMINUM
- ALL EXTERIOR WASHERS SHALL BE SEALING WASHERS
- THE FOLLOWING WEATHER STRIPPING SHALL BE USED FOR THE FOLLOWING APPLICATIONS:
DOOR LIP - TRIMLOCK 3100B3X18C
FAN PLATES - STICKER-ITL 15838
- ACS - STICKER-ITL 146314
- CUSTOM ENCLOSURES SHALL HAVE SECURITY TORX FOR ALL EXTERIOR HARDWARE
- SYMBOL \odot DENOTES CRITICAL DIMENSIONS AND MUST BE INSPECTED
- REMOVE ALL BURRS AND BEAMP EDGES 0.03" MAX RADIUS OR CHAMFER
- DO NOT DRIBBER PRESS FIT HOLES
- DIMENSIONS SHALL APPLY AFTER ALCOHOL PAINT FINISH OR COAT IS APPLIED
- INSTALL PRESS FIT STANDOFFS, STUDS, AND NUTS IN ACCORDANCE WITH THE MANUFACTURER'S SPECIFICATIONS
- ALL OPEN HOLES SHALL BE POPULATED WITH APPLICABLE HARDWARE
- IDENTIFY PART WITH PART NUMBER, REVISION LETTER, AND SERIAL NUMBER
- FINISHED PART TO BE FREE OF OILS, LUBRICANTS, AND OTHER CONTAMINANTS
- NO NUTS OR LOCK NUTS TO BE USED ON ANY PEM STUDS, UNLESS OTHERWISE SPECIFIED
- ALL PEM STUDS WILL BE SECURED WITH EXTERNAL TOOTH WASHER AND STANDARD NUTS
- TOLERANCES UNLESS OTHERWISE SPECIFIED:
a. HOLE SIZE \rightarrow +0.003"
b. HOLE TO HOLE \rightarrow +0.005"
c. HOLE TO EDGE \rightarrow +0.010"
d. HOLE TO FOLD \rightarrow +0.005"
e. FOLD TO FOLD \rightarrow +0.020"

WEB DRAWING (NOT FOR FABRICATION)



UNLESS OTHERWISE SPECIFIED:
DIMENSION AND UNIT: INCH
ARTICLE NO: 0000000000
REV: 0000000000
DATE: 0000000000
FILE: 0000000000
TIME: 0000000000

NAME	DATE	DDB Unlimited Inc.			
Model by: 0000	12/19/14	SV#XXXXXX			
Drawn by: 0000	05/13/16	SV#302410			
Sales Rep: 0000	05/13/16	SHE	Cage Code:	DWG. NO.:	REV
Q.A. Appr: 0000	05/13/16	D	88515	01101	B
Prod.Mgr: 0000	05/13/16	SCALE: 1:8	WEIGHT: 44 lbs.	SHEET 01/1	

ISO 9001 REGISTERED COMPANY
Certificate NO. 7252

DO NOT SCALE DRAWING

THE INFORMATION CONTAINED IN THIS DRAWING IS THE SOLE PROPERTY OF DDB Unlimited, INC. ANY REPRODUCTION IN PART OR AS A WHOLE WITHOUT THE WRITTEN PERMISSION OF DDB Unlimited, INC. IS PROHIBITED.

DDB FORM 7-12-REV11 04/25/13