



An ISO 9001/27001  
Certified company

# UL Listed SOD Series

## SOD-192420-UL50



### Why Choose SOD the Series?

The SOD series enclosure is the ultimate choice for your outdoor equipment racking applications when versatility is needed. Being constructed of our Alumiflex® material, you'll find it noticeably lighter than steel, yet strong enough to rack even the heaviest equipment. When choosing the SOD series, ease of installation along with pad, pole and wall mounting options provide endless possibilities for where you can locate. With many standard features including 3-point locking system, frame gasket, grounding strap, and top solar shield; you will see the value quickly add up. Add to this a long list of available options including HVAC climate controls, electrical and cable entry solutions allows the SOD series to provide a flexibility of options that are second to none. All this with industry best lead times and competitive pricing as you have come to expect with DDB. The SOD series... a versatile, scalable design to meet a wide array of situations.



### Features

- 0.125" Aluminum Construction
- Stainless Steel External Hardware/Hinge
- Heavy Duty Out-Door Construction
- Pad/Wall/Pole Mountable
- Front Door Access
- Welded Construction
- Cream Powder-Coat in Stock
- Flexible and Scalable
- 15 Year Warranty
- Quick Shipping

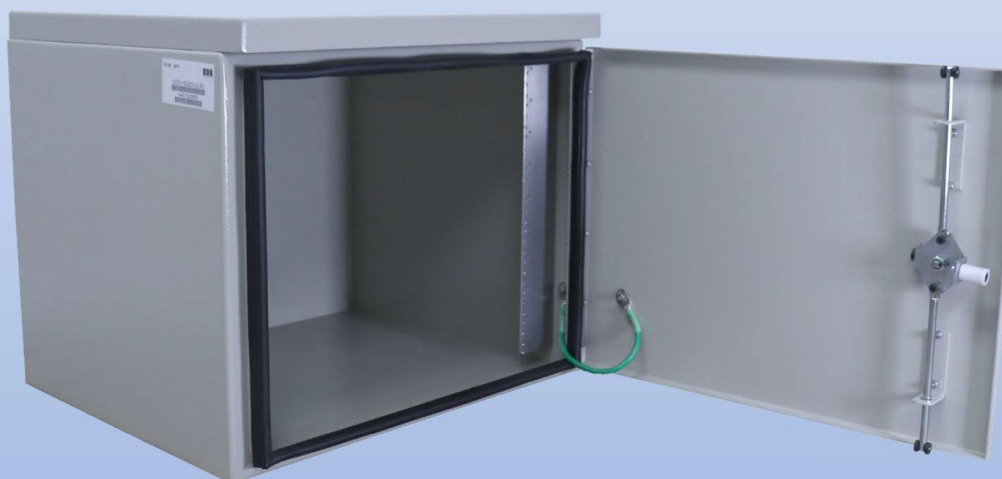

### Application Types

- Telecommunications
- Wireless/Broadband
- Fiber Optics
- Back Haul
- Small Cell/DAS
- Utility
- Base Station
- Military
- Trailer-Based Communications
- Wi-Fi
- LTEE/4G/5G

### Industry Standards:

UL 50/50E Type 4 Listed

### Weight and Dimensions

Approximate Exterior Enclosure Dimensions:

21"H x 24"W x 24"D

Shipping Dimensions:

32"W x 32"L Palletized

Approximate Shipping Weight:

72 lbs.

2301 S. HWY 77 Pauls Valley, OK 73075

T: (800) 753-8459 – F: (877) 220-7236

[sales@ddbunlimited.com](mailto:sales@ddbunlimited.com) [www.ddbunlimited.com](http://www.ddbunlimited.com)

# UL Listed SOD Series

## SOD-192420-UL50

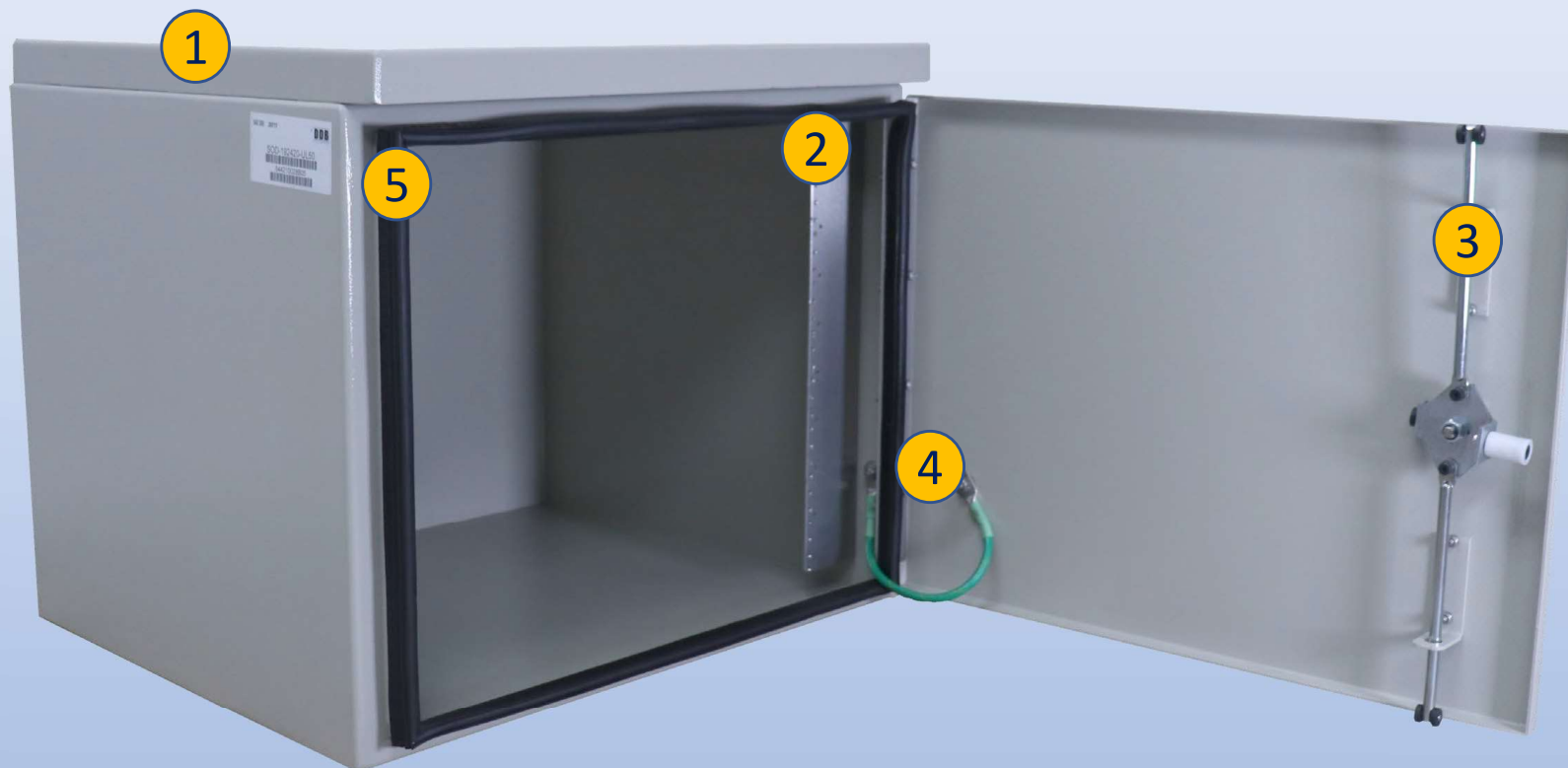

### Features

1. Solar Shield (Alumishield)
2. 19" Racking Rails
3. 3-point locking system
4. Grounding Strap - UL Listed
5. Frame gasket - UL Listed

2301 S. HWY 77 Pauls Valley, OK 73075

T: (800) 753-8459 – F: (877) 220-7236

[sales@ddbunlimited.com](mailto:sales@ddbunlimited.com) [www.ddbunlimited.com](http://www.ddbunlimited.com)

WEB DRAWING (NOT FOR FABRICATION)

| REVISIONS |                                      |          |
|-----------|--------------------------------------|----------|
| REV.      | DESCRIPTION                          | DATE     |
| A         | CREATED WEBSITE DRAWING PER DR-02035 | 6/5/2019 |

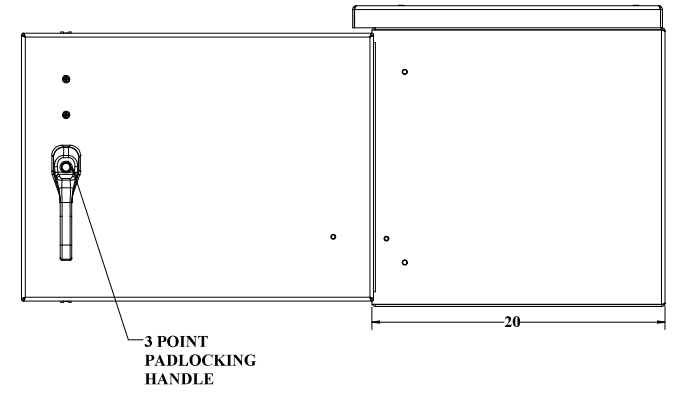
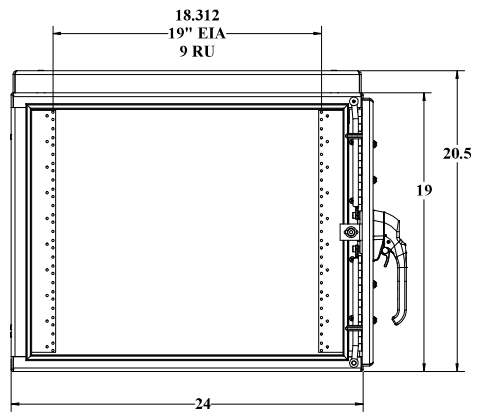
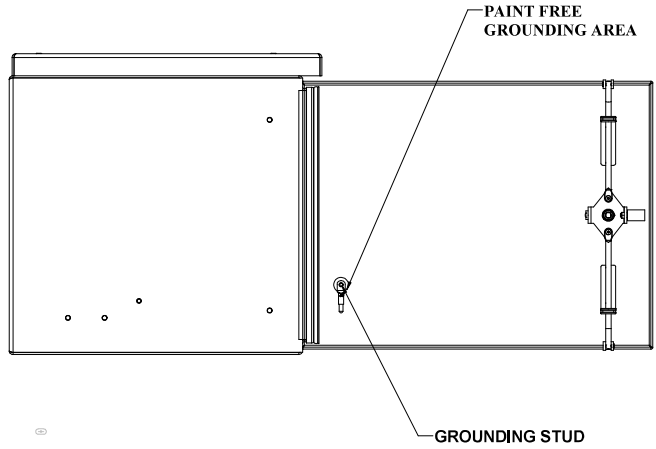
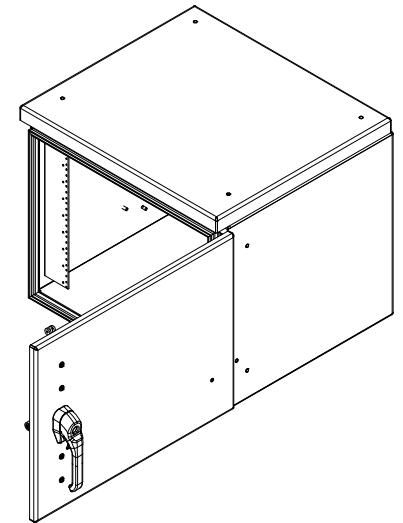
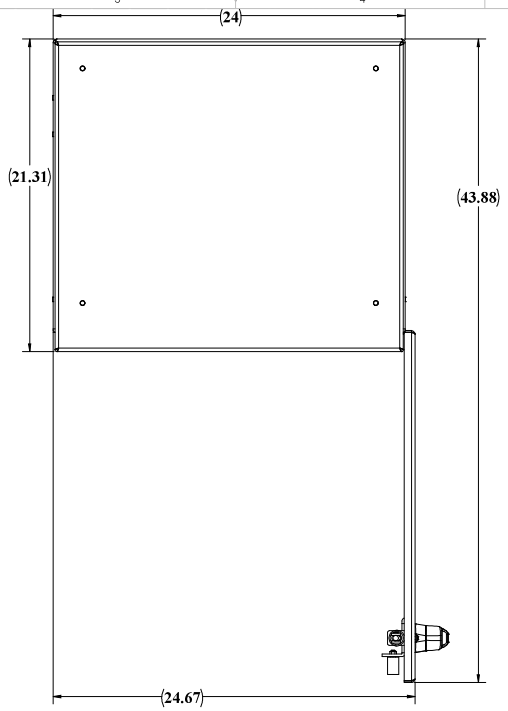

WEB DRAWING (NOT FOR FABRICATION)

| UNLESS OTHERWISE SPECIFIED:   |            | NAME     | DATE     | <b>DDB Unlimited Inc.</b> |           |          |              |
|-------------------------------|------------|----------|----------|---------------------------|-----------|----------|--------------|
| Dimensions (inches or metric) | Model No.  | 0208     |          | SOD-XXXX-UL50             |           |          |              |
| Particulars                   | Drawn By   | Manus    | 06/05/19 | SOD-192420-UL50           |           |          |              |
| Material                      | Sales Rep  | Advantek |          | SHE                       | Cage Code | DWG. NO. | REV          |
| Quantity                      | Q.A. Appr. | Stevens  | 06/21/19 | D                         | 38515     | 02035    | A            |
| Finish                        | Prod. Mgr. | Chalk    | 07/18/19 | SCALE: 1:8                |           | WEB-DWG  | 1/8          |
| Notes                         | Checked    |          |          |                           |           |          | SHEET 1 OF 2 |

THE INFORMATION CONTAINED IN THIS DRAWING IS THE SOLE PROPERTY OF DDB Unlimited, INC. ANY REPRODUCTION IN PART OR AS A WHOLE WITHOUT THE WRITTEN PERMISSION OF DDB Unlimited, INC. IS PROHIBITED.

DDB FORM 7.1-2 REV.F 05/02/19

DDB FORM 7-1-2 REV. A (08/02/17)

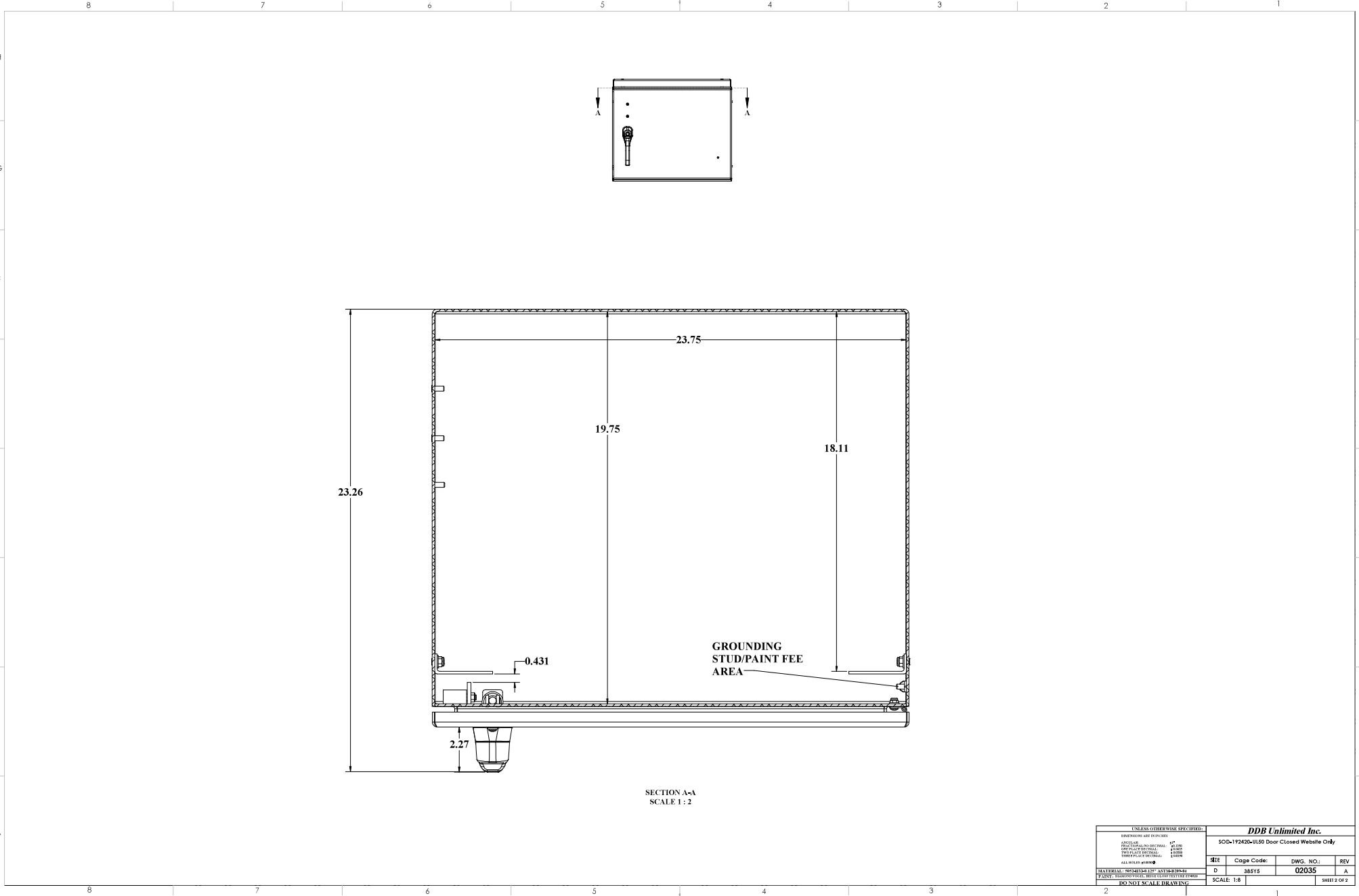

SECTION A-A  
SCALE 1:2

| UNLESS OTHERWISE SPECIFIED:                            |       |  |        |
|--|-------|--|--------|
| DIMENSIONS ARE IN INCHES                               |       | SOD-192420-UL50 Door Closed Website Only |        |
| ANGLE  | 1°    | REV                                      |        |
| DIAMETER   | 0.000 | DWG. NO.                                 | 02035  |
| DEPTH  | 0.000 | CODE                                     | 38515  |
| DRILL POINT  | 1.000 | SCALE                                    | 1:8    |
| DRILL FLUTE  | 1.000 | SHEET                                    | 2 OF 2 |
| ALL DIMENSIONS ARE UNLESS OTHERWISE SPECIFIED          |       |  |        |
| MATERIAL SPECIFICATIONS ARE UNLESS OTHERWISE SPECIFIED |       |  |        |
| PAINT FINISHES ARE UNLESS OTHERWISE SPECIFIED          |       |  |        |
| DO NOT SCALE DRAWING                                   |       |  |        |

DDB, DDB PART, AND DDB UNLIMITED INC. ARE THE SOLE PROPERTY OF DDB UNLIMITED, INC. ANY REPRODUCTION IN PART OR AS A WHOLE WITHOUT THE WRITTEN PERMISSION OF DDB UNLIMITED, INC. IS PROHIBITED.