



An ISO 9001
Certified company

OD-UL Series

OD-50DXC-UL50

Made in America



Believing in American
Craftsmanship



Why Choose the OD-UL Series?

The OD-UL series of enclosures are the ultimate choice for your outdoor racking requirements. Being made of our own rugged Alumiflex®, you'll find it noticeably lighter than steel, yet strong enough to rack even the heaviest equipment. When choosing the OD-UL series, you have handpicked the highest value in American construction. The OD-UL series includes the standard features you have come to expect with DDB, incorporating the versatile strut system for adjustable racking, the security of a 3- point locking system, our patented Alumishield® solar cap to manage heat loads, UL listed grounding straps, & UL listed gasketing. For those who need more than just our standard enclosure, DDB can also make a truly customized solution with our many available options including HVAC, providing a climate-controlled environment for any electronic equipment, electrical load panels and cable entry solutions to name a few. All of this comes together to create an enclosure able to meet all of the unique needs your customers have been seeking. DDB offers a state-of-the-art design, a competitive price, benchmark lead times and a guaranteed delivery, all backed up with an industry leading 15-year warranty on every enclosure. Put DDB's substantial stock to work for you today. Contact our professional staff to assist you with your made-to-order solution.

Application Types

- Telecommunications
- Wireless/Broadband
- Fiber Optics
- Back Haul
- Small Cell/DAS
- Public Safety
- Utility
- Base Station
- Military
- Trailer-Based Communications
- Wi-Fi
- LTEE/4G/5G



Environmental & Safety Ratings:

- ✓ ETL environmentally listed to UL 50/50E, IP 66, NEMA Type 4
- ✓ ETL listed; Safety Requirements, UL 62368-1:2019 Ed.3, CSA C22.2

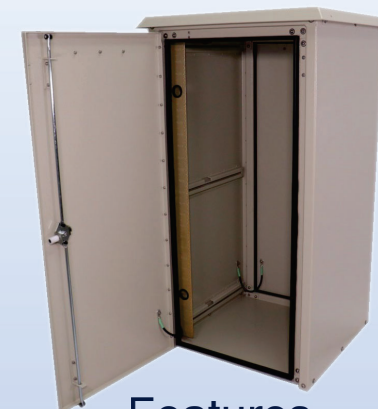

Features

- 0.125" Aluminum Construction
- Stainless Steel External Hardware/Hinge
- Fully Welded Construction
- 3 Point Lock System
- Front and Rear Access
- Custom Colors Available
- Cream and Red Powder-Coat in Stock
- Flexible and Scalable
- 15 Year Warranty
- Quick Shipping
- Water/Rain/Sleet/Dust Tight

Weight and Dimensions

- Approximate Exterior Enclosure Dimensions:
- 51"H x 28"W x 30"D
- Shipping Dimensions:
- 35"W x 42"L - Palletized
- Approximate Shipping Weight:
- 160 lbs.

2301 S. HWY 77 Pauls Valley, OK 73075

T: (800) 753-8459 – F: (877) 220-7236

sales@ddbunlimited.com www.ddbunlimited.com

OD-UL Series

OD-50DXC-UL50



Features

1. Solar Shield (Alumishield)
2. 1 Set of 19" Adjustable Racking Rails, 26 RU's
3. Rear Access Door
4. 3 Point Locking System
5. Bonding Strap - UL Listed
6. Frame Gasket - UL Listed

2301 S. HWY 77 Pauls Valley, OK 73075
T: (800) 753-8459 – F: (877) 220-7236
sales@ddbunlimited.com www.ddbunlimited.com



Installation, operating and
safety instructions can be
downloaded here



Scan this code for
replacement parts



WEB DRAWING (NOT FOR FABRICATION)

REVISIONS		
REV.	DESCRIPTION	DATE
A	CREATED WEBSITE DRAWING FOR OD-50DX-UL50 PER DR-01849	9/26/2018
B	UPDATED SHEET FORMAT	3/30/2022

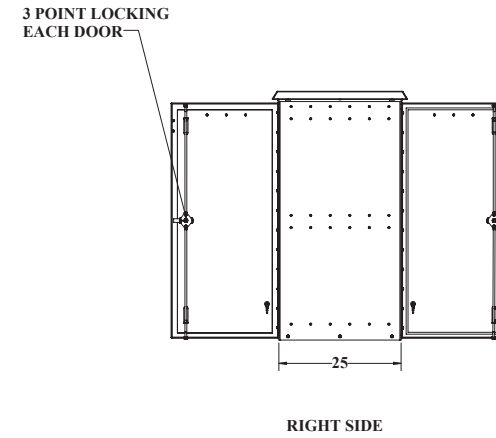
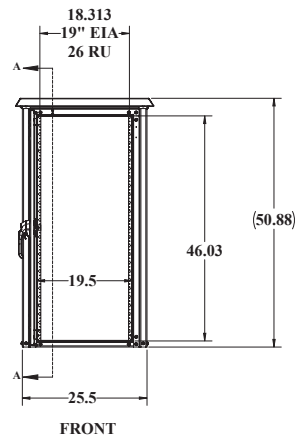
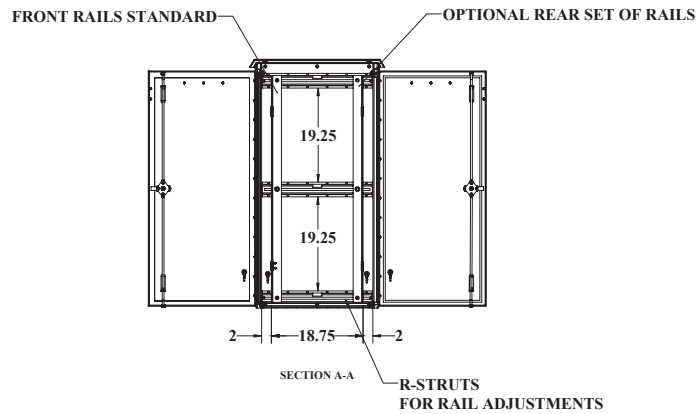
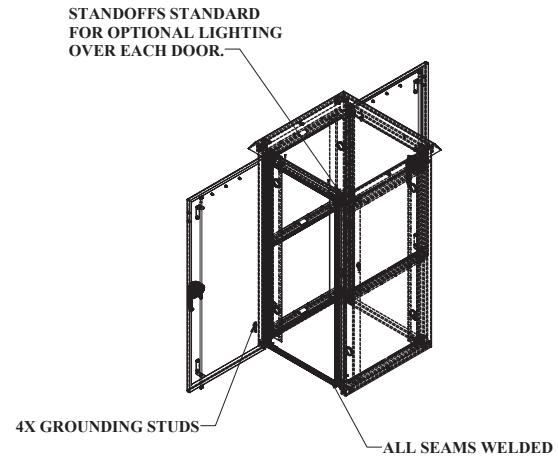
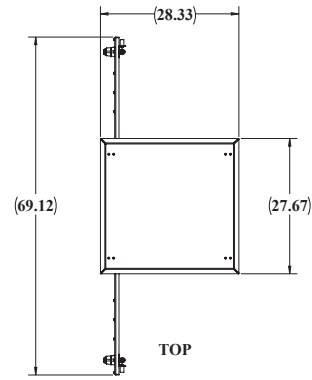

WEB DRAWING (NOT FOR FABRICATION)

UNLESS OTHERWISE SPECIFIED:		NAME	DATE	DDB Unlimited Inc.			
ANGULAR	30°	Model By:	09/26/2018	OD-XXXX-UL50			
FINISH	AS SHOWN	Drawn By:	03/30/22	Enclosure, OD, 50, DX, UL50			
WELDING	AS SHOWN	Sales Rep:	Complete	SIZE	Cage Code:	DWG. NO.:	REV
MATERIAL:	304 STAINLESS STEEL	Q.A. Appr:	04/14/22	D	385YS	01849	8
PAINT:	AS SHOWN	Prod.Mgr./ Clerk:	04/14/22	SCALE:	1:12	WGHT:	122 lbs.
DO NOT SCALE DRAWING				SHEET 1 OF 3			

UNCLASSIFIED PUBLIC

DDB FORM: 7-1-2 REV/F 05/02/19

4X $\phi \frac{5}{32}$ "
ETCHING

$\phi .22$
FLOOR ETCHING

$19 \frac{1}{2}$ "
FLOOR ETCHING

$29 \frac{5}{8}$ "

18.75
RAIL TO RAIL

20.6

$23 \frac{5}{8}$ "
R-STRUT TO R-STRUT

(2.26)

TOP VIEW CEILING AND ALUMASHIELD NOT SHOWN

UNLESS OTHERWISE SPECIFIED:		DDB Unlimited Inc.			
DIMENSIONS ARE IN INCHES		GD-DX-Closed			
WEIGHT	1.125	Facilities: 09, DX, 11, 59, Closed			
TEMPERATURE	1.125	SIZE	Code Code:	DWG. NO.:	REV
TEMPERATURE	1.125	D	385YS	01849	8
TEMPERATURE	1.125	SCALE	1:12	WEIGHT	87 lbs.
TEMPERATURE	1.125	DDB NOT SCALE DRAWING		SHEET 2 OF 3	

UNCLASSIFIED PUBLIC

DDB FORM: 7.1.2-REVAK 08/02/17

DOOR GASKET HIDDEN

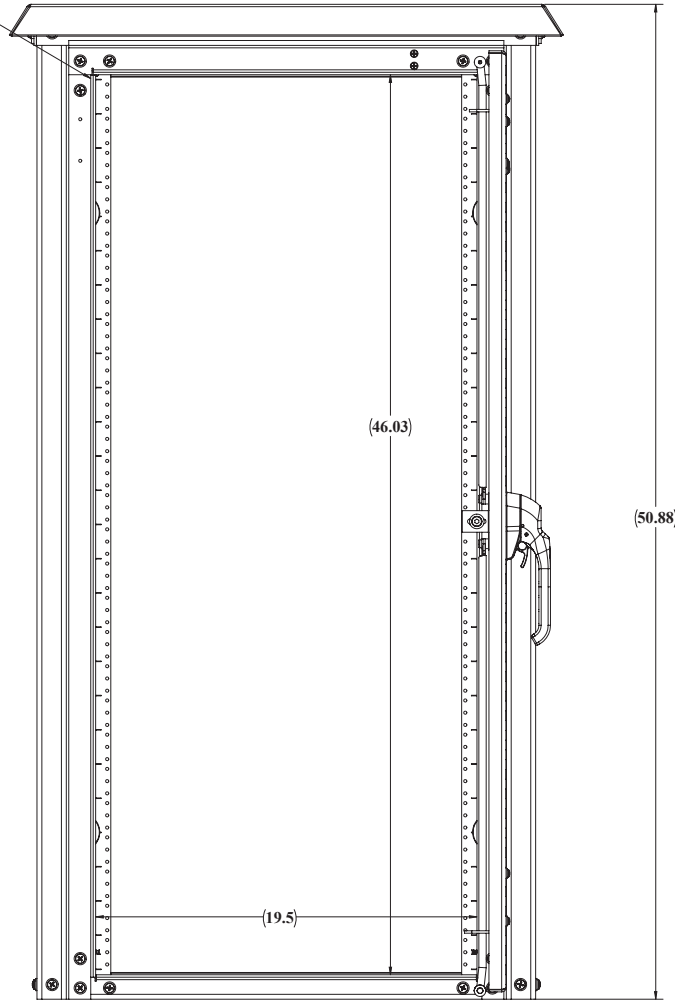

BACK VIEW

UNLESS OTHERWISE SPECIFIED:			
DIMENSIONS ARE IN INCHES			
FINISH	STAINLESS STEEL	1"	
DRILLING	STAINLESS STEEL	1/8"	
DRILLING	STAINLESS STEEL	1/8"	
DRILLING	STAINLESS STEEL	1/8"	
ALL DIMENSIONS PER DWG			
MATERIALS AND FINISHES PER DWG			
PAINT: Diamond Vinyl Edge Glass Finish P.F. 333			
DO NOT SCALE DRAWING			
DDB Unlimited Inc.			
CD-500X-UL50			
Eastmore, OH, US, 11.1.19			
SIZE	Code Code:	DWG. NO.:	REV
D	385YS	01849	8
SCALE: 1:12		WEIGHT: 122 lbs.	SHEET 2 OF 3

UNCLASSIFIED PUBLIC