



An ISO 9001/27001
Certified company

UL-OD Series

OD-62DDXC-UL50



Why Choose The UL-OD Series?

The UL-OD series of enclosures are the ultimate choice for your outdoor racking requirements. Being made of our own rugged Alumiflex®, you'll find it noticeably lighter than steel, yet strong enough to rack even the heaviest equipment. When choosing the UL-OD series, you have handpicked the highest value in American construction. The UL-OD series includes the standard features you have come to expect with DDB, incorporating the versatile strut system for adjustable racking, the security of a 3- point locking system and our patented Alumishield® solar cap to manage heat loads. For those who need more than just our standard enclosure, DDB can also make a truly customized solution with our many available options including HVAC, providing a climate-controlled environment for any electronic equipment, electrical load panels and cable entry solutions to name a few. All of this comes together to create an enclosure able to meet all of the unique needs your customers have been seeking. DDB offers a state-of-the-art design, a competitive price, benchmark lead times and a guaranteed delivery, all backed up with an industry leading 15-year warranty on every enclosure. Put DDB's substantial stock to work for you today. Contact our professional staff to assist you with your made-to-order solution.



Features

- 0.125" Aluminum Construction
- Stainless Steel External Hardware/Hinge
- Fully Welded Construction
- 3 Point Lock System
- Front and Rear Access
- Custom Colors Available
- Cream and Red Powder-Coat in Stock
- Flexible and Scalable
- 15 Year Warranty
- Quick Shipping



Environmental & Safety Ratings:

- ✓ ETL environmentally listed to UL 50/50E, IP 66, Type 4
- ✓ ETL listed; Safety Requirements, UL 62368-1:2019 Ed.3, CSA C22.2

Application Types

- Telecommunications
- Wireless/Broadband
- Fiber Optics
- Back Haul
- Small Cell/DAS
- Public Safety
- Utility
- Base Station
- Military
- Trailer-Based Communications
- Wi-Fi
- LTEE/4G/5G

2301 S. HWY 77 Pauls Valley, OK 73075
T: (800) 753-8459 – F: (877) 220-7236

sales@ddbunlimited.com www.ddbunlimited.com

Weight and Dimensions

- Approximate Exterior Enclosure Dimensions:
63"H x 28"W x 47"D
- Shipping Dimensions:
35"W x 52"L - Palletized
- Approximate Shipping Weight:
233 lbs.

UL-OD Series

OD-62DDXC-UL50

Made in America



Believing in American
Craftsmanship

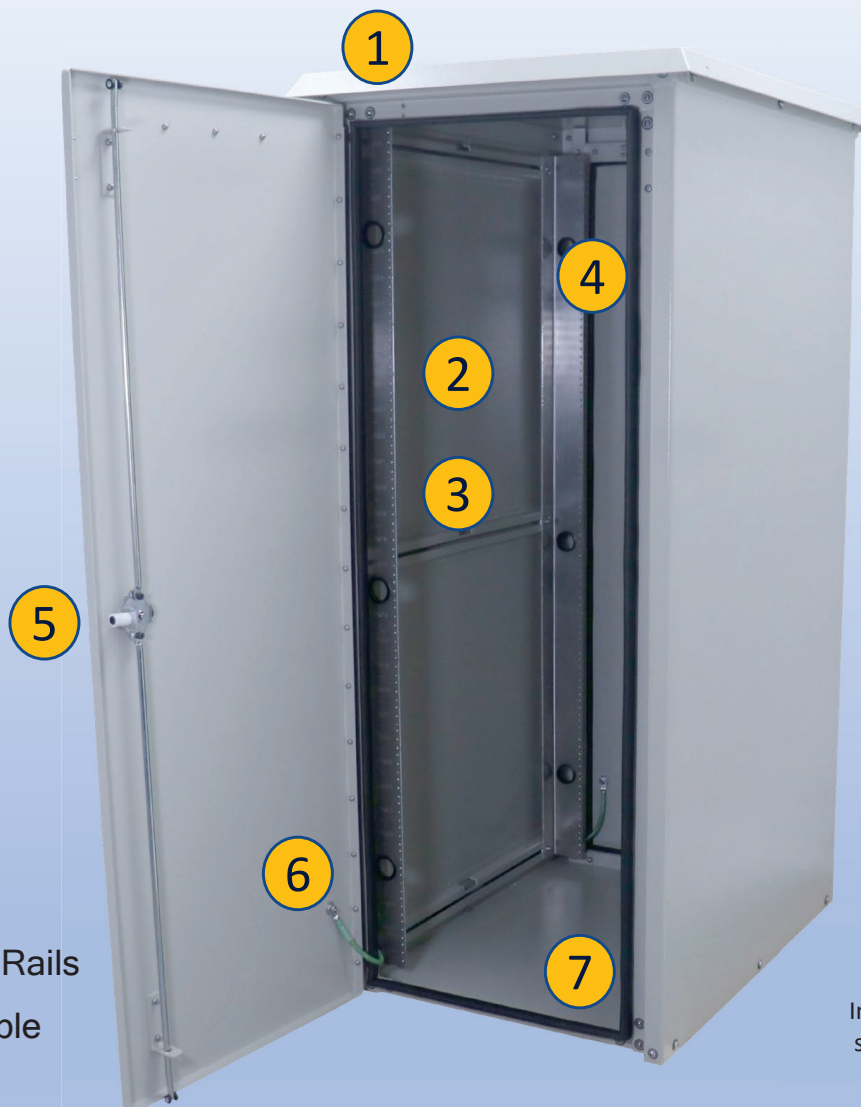

Features

1. Alumishield
2. 2 Sets of 19" Adjustable Racking Rails
3. 33 Racking Units, 66 RU's available
4. Rear Access Door
5. 3 Point Locking System
6. Bonding Strap - UL Listed
7. Frame Gasket - UL Listed



Installation, operating and
safety instructions can be
downloaded here



Scan this code for
replacement parts



2301 S. HWY 77 Pauls Valley, OK 73075

T: (800) 753-8459 – F: (877) 220-7236

sales@ddbunlimited.com www.ddbunlimited.com

WEB DRAWING (NOT FOR FABRICATION)

REVISIONS		
REV.	DESCRIPTION	DATE
A	CREATED WEBSITE DRAWING FOR OD-62DDX-UL50 PER DR-01854	10/5/2018
B	UPDATED SHEET FORMAT	4/15/2022

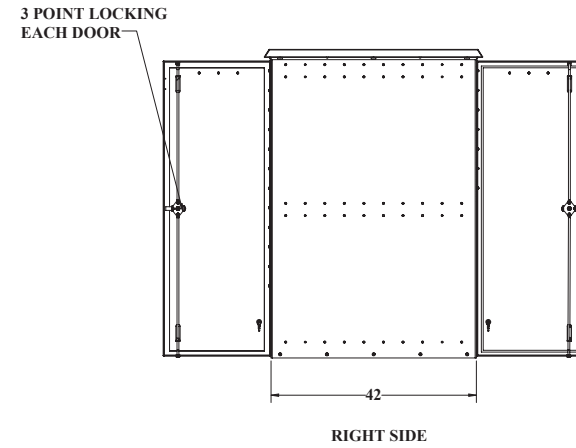
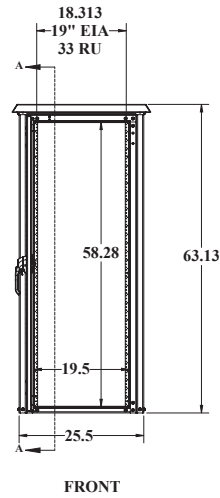
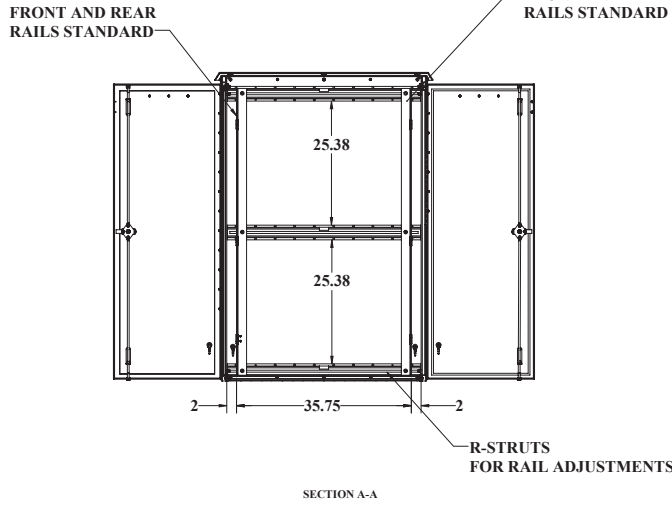
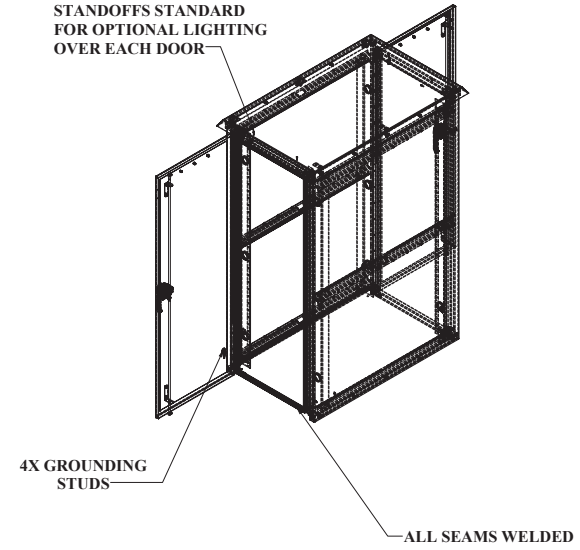
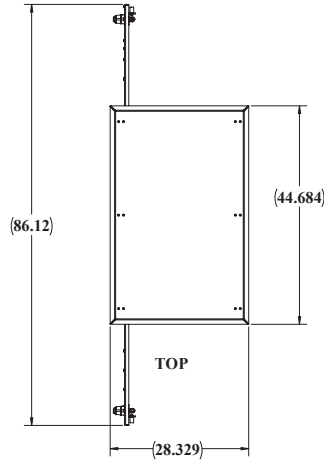

WEB DRAWING (NOT FOR FABRICATION)

UNLESS OTHERWISE SPECIFIED:		NAME	DATE	DDB Unlimited Inc.			
ANGULAR	90°	Model by:	03/18/18	OD-XXXX-UL50			
FINISH	As Shown	Drawn by:	06/15/22	Enclosure: OD_62_DDX_UL50			
TOLERANCE	±0.005	Sales Rep:	Complete	SIZE	Cage Code:	DWG. NO.:	REV
MATERIAL:	304 STAINLESS STEEL	Q.A. Appr.:	04/18/22	D	385YS	01854	8
PAINT:	None	Prod. Mgr.:	04/18/22	SCALE:	1:12	WGHT:	190 lbs.
DO NOT SCALE DRAWING		Sheet Number:		SHEET 1 OF 3			

UNCLASSIFIED PUBLIC

DDB FORM: 7-1-2 REV: F 05/02/19

8 7 6 5 4 3 2 1

H G F E D C B A

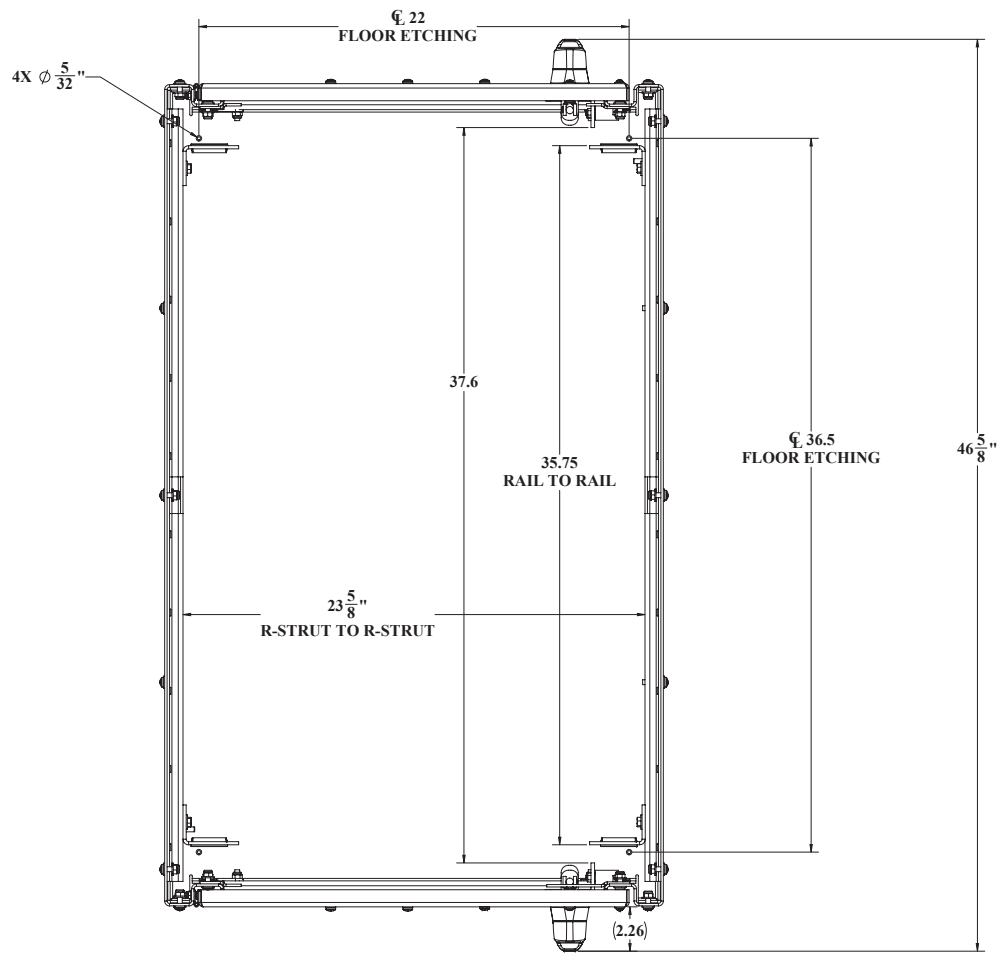

TOP VIEW CEILING AND ALUMASHIELD NOT SHOWN

UNLESS OTHERWISE SPECIFIED:		<i>DDB Unlimited Inc.</i>	
FINISH	GRAND PRIME	QQ-DX-Closed	Engineers: OHS, DIX, LLSH, Closed
PAINT	PRIMER: ZINCPREPRIM	SIZE	Code Code: DWG. NO.: REV
	PRIMER: ZINCPREPRIM	D	388YS 01854 8
	PRIMER: ZINCPREPRIM	SCALE 1:12	WEIGHT: 120 lbs.
	PRIMER: ZINCPREPRIM	SHEET 2 OF 3	

UNCLASSIFIED PUBLIC

DD8 FORM: 7.1.2-REVAK 08/02/17

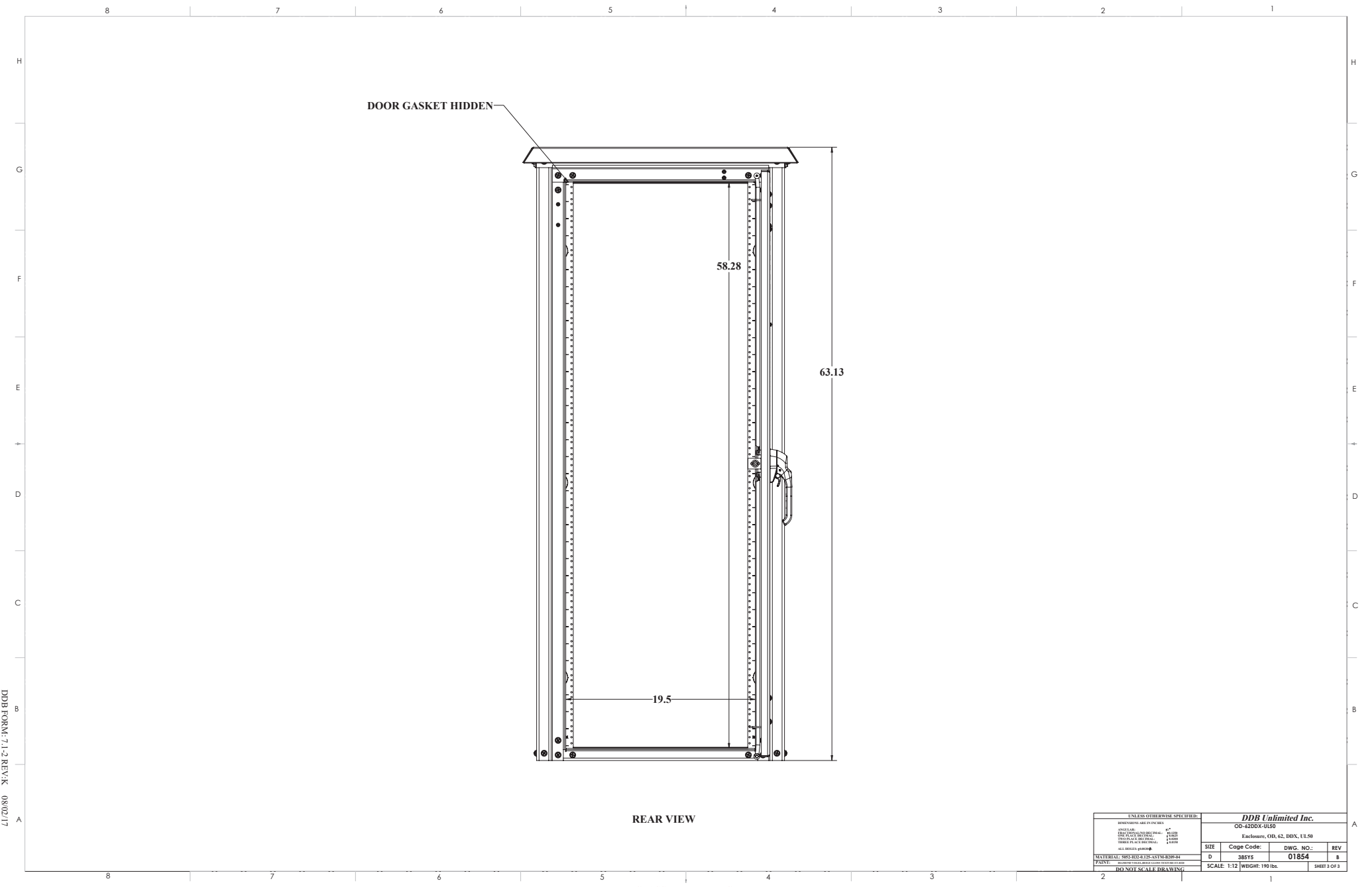

REAR VIEW

UNCLASSIFIED PUBLIC

UNLESS OTHERWISE SPECIFIED:		DDB Unlimited Inc.	
DIMENSIONS ARE IN INCHES		OD-420DX-UL50	
FINISH	STAIN	SIZE	Code Code: DWG. NO.: REV
303	303	D	385YS 01854 8
304	304	SCALE 1:12 WEIGHT 190 lbs. SHEET 3 OF 3	
305	305	DDB UNLIMITED INC. 2018	
306	306	DDB UNLIMITED INC. 2018	
307	307	DDB UNLIMITED INC. 2018	
308	308	DDB UNLIMITED INC. 2018	
309	309	DDB UNLIMITED INC. 2018	
310	310	DDB UNLIMITED INC. 2018	
311	311	DDB UNLIMITED INC. 2018	
312	312	DDB UNLIMITED INC. 2018	
313	313	DDB UNLIMITED INC. 2018	
314	314	DDB UNLIMITED INC. 2018	
315	315	DDB UNLIMITED INC. 2018	
316	316	DDB UNLIMITED INC. 2018	
317	317	DDB UNLIMITED INC. 2018	
318	318	DDB UNLIMITED INC. 2018	
319	319	DDB UNLIMITED INC. 2018	
320	320	DDB UNLIMITED INC. 2018	
321	321	DDB UNLIMITED INC. 2018	
322	322	DDB UNLIMITED INC. 2018	
323	323	DDB UNLIMITED INC. 2018	
324	324	DDB UNLIMITED INC. 2018	
325	325	DDB UNLIMITED INC. 2018	
326	326	DDB UNLIMITED INC. 2018	
327	327	DDB UNLIMITED INC. 2018	
328	328	DDB UNLIMITED INC. 2018	
329	329	DDB UNLIMITED INC. 2018	
330	330	DDB UNLIMITED INC. 2018	
331	331	DDB UNLIMITED INC. 2018	
332	332	DDB UNLIMITED INC. 2018	
333	333	DDB UNLIMITED INC. 2018	
334	334	DDB UNLIMITED INC. 2018	
335	335	DDB UNLIMITED INC. 2018	
336	336	DDB UNLIMITED INC. 2018	
337	337	DDB UNLIMITED INC. 2018	
338	338	DDB UNLIMITED INC. 2018	
339	339	DDB UNLIMITED INC. 2018	
340	340	DDB UNLIMITED INC. 2018	
341	341	DDB UNLIMITED INC. 2018	
342	342	DDB UNLIMITED INC. 2018	
343	343	DDB UNLIMITED INC. 2018	
344	344	DDB UNLIMITED INC. 2018	
345	345	DDB UNLIMITED INC. 2018	
346	346	DDB UNLIMITED INC. 2018	
347	347	DDB UNLIMITED INC. 2018	
348	348	DDB UNLIMITED INC. 2018	
349	349	DDB UNLIMITED INC. 2018	
350	350	DDB UNLIMITED INC. 2018	
351	351	DDB UNLIMITED INC. 2018	
352	352	DDB UNLIMITED INC. 2018	
353	353	DDB UNLIMITED INC. 2018	
354	354	DDB UNLIMITED INC. 2018	
355	355	DDB UNLIMITED INC. 2018	
356	356	DDB UNLIMITED INC. 2018	
357	357	DDB UNLIMITED INC. 2018	
358	358	DDB UNLIMITED INC. 2018	
359	359	DDB UNLIMITED INC. 2018	
360	360	DDB UNLIMITED INC. 2018	
361	361	DDB UNLIMITED INC. 2018	
362	362	DDB UNLIMITED INC. 2018	
363	363	DDB UNLIMITED INC. 2018	
364	364	DDB UNLIMITED INC. 2018	
365	365	DDB UNLIMITED INC. 2018	
366	366	DDB UNLIMITED INC. 2018	
367	367	DDB UNLIMITED INC. 2018	
368	368	DDB UNLIMITED INC. 2018	
369	369	DDB UNLIMITED INC. 2018	
370	370	DDB UNLIMITED INC. 2018	
371	371	DDB UNLIMITED INC. 2018	
372	372	DDB UNLIMITED INC. 2018	
373	373	DDB UNLIMITED INC. 2018	
374	374	DDB UNLIMITED INC. 2018	
375	375	DDB UNLIMITED INC. 2018	
376	376	DDB UNLIMITED INC. 2018	
377	377	DDB UNLIMITED INC. 2018	
378	378	DDB UNLIMITED INC. 2018	
379	379	DDB UNLIMITED INC. 2018	
380	380	DDB UNLIMITED INC. 2018	
381	381	DDB UNLIMITED INC. 2018	
382	382	DDB UNLIMITED INC. 2018	
383	383	DDB UNLIMITED INC. 2018	
384	384	DDB UNLIMITED INC. 2018	
385	385	DDB UNLIMITED INC. 2018	
386	386	DDB UNLIMITED INC. 2018	
387	387	DDB UNLIMITED INC. 2018	
388	388	DDB UNLIMITED INC. 2018	
389	389	DDB UNLIMITED INC. 2018	
390	390	DDB UNLIMITED INC. 2018	
391	391	DDB UNLIMITED INC. 2018	
392	392	DDB UNLIMITED INC. 2018	
393	393	DDB UNLIMITED INC. 2018	
394	394	DDB UNLIMITED INC. 2018	
395	395	DDB UNLIMITED INC. 2018	
396	396	DDB UNLIMITED INC. 2018	
397	397	DDB UNLIMITED INC. 2018	
398	398	DDB UNLIMITED INC. 2018	
399	399	DDB UNLIMITED INC. 2018	
400	400	DDB UNLIMITED INC. 2018	
401	401	DDB UNLIMITED INC. 2018	
402	402	DDB UNLIMITED INC. 2018	
403	403	DDB UNLIMITED INC. 2018	
404	404	DDB UNLIMITED INC. 2018	
405	405	DDB UNLIMITED INC. 2018	
406	406	DDB UNLIMITED INC. 2018	
407	407	DDB UNLIMITED INC. 2018	
408	408	DDB UNLIMITED INC. 2018	
409	409	DDB UNLIMITED INC. 2018	
410	410	DDB UNLIMITED INC. 2018	
411	411	DDB UNLIMITED INC. 2018	
412	412	DDB UNLIMITED INC. 2018	
413	413	DDB UNLIMITED INC. 2018	
414	414	DDB UNLIMITED INC. 2018	
415	415	DDB UNLIMITED INC. 2018	
416	416	DDB UNLIMITED INC. 2018	
417	417	DDB UNLIMITED INC. 2018	
418	418	DDB UNLIMITED INC. 2018	
419	419	DDB UNLIMITED INC. 2018	
420	420	DDB UNLIMITED INC. 2018	
421	421	DDB UNLIMITED INC. 2018	
422	422	DDB UNLIMITED INC. 2018	
423	423	DDB UNLIMITED INC. 2018	
424	424	DDB UNLIMITED INC. 2018	
425	425	DDB UNLIMITED INC. 2018	
426	426	DDB UNLIMITED INC. 2018	
427	427	DDB UNLIMITED INC. 2018	
428	428	DDB UNLIMITED INC. 2018	
429	429	DDB UNLIMITED INC. 2018	
430	430	DDB UNLIMITED INC. 2018	
431	431	DDB UNLIMITED INC. 2018	
432	432	DDB UNLIMITED INC. 2018	
433	433	DDB UNLIMITED INC. 2018	
434	434	DDB UNLIMITED INC. 2018	
435	435	DDB UNLIMITED INC. 2018	
436	436	DDB UNLIMITED INC. 2018	
437	437	DDB UNLIMITED INC. 2018	
438	438	DDB UNLIMITED INC. 2018	
439	439	DDB UNLIMITED INC. 2018	
440	440	DDB UNLIMITED INC. 2018	
441	441	DDB UNLIMITED INC. 2018	
442	442	DDB UNLIMITED INC. 2018	
443	443	DDB UNLIMITED INC. 2018	
444	444	DDB UNLIMITED INC. 2018	
445	445	DDB UNLIMITED INC. 2018	
446	446	DDB UNLIMITED INC. 2018	
447	447	DDB UNLIMITED INC. 2018	
448	448	DDB UNLIMITED INC. 2018	
449	449	DDB UNLIMITED INC. 2018	
450	450	DDB UNLIMITED INC. 2018	

DDB FORM 7.1.2-REV.A 08/02/17