

Mounting Feet

2OD-MTFT



Why Choose the 2OD Mounting feet for your enclosure?

Does your enclosure need extra stability? Do you need the extra security, bolt down mounting feet offer? When it comes to pad mounting, look no further than DDB's 2OD Mounting feet! All of our mounting feet can be installed onto your enclosure by our professional in-house technicians guaranteeing a perfect fit every time, with an additional benefit of saving you time and money allowing you to focus on what is important. Contact our professional staff to assist you with your made-to-order solution today!

Application Types

- OD Line
- 2OD Line
- 3OD Line
- WOD Line
- Cabinet bases above 3"



Features

- .125" Fully welded construction
- Welded corner brackets inside
- Flexible and Scalable
- 15 Year Warranty
- Quick Shipping
- Set of 4, hardware included

Weight and Dimensions

- Approximate Exterior Dimensions:
3.375"W x 3"D x 5.875" H
- Shipping Dimensions:
12 x 8 x 8 Boxed
- Approximate Shipping Weight:
5 lbs.

2301 S. HWY 77 Pauls Valley, OK 73075
T: (800) 753-8459 – F: (877) 220-7236

sales@ddbunlimited.com www.ddbunlimited.com

WEB DRAWING (NOT FOR FABRICATION)

REVISIONS		
REV.	DESCRIPTION	DATE
A	WEB FOR ZP-20D-MTFT	3/22/2021

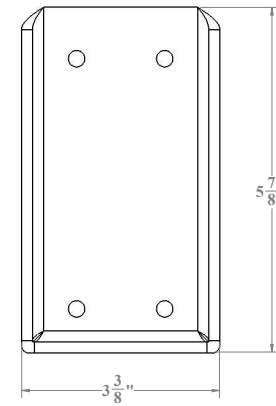
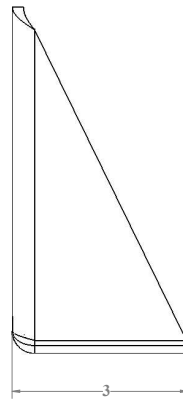
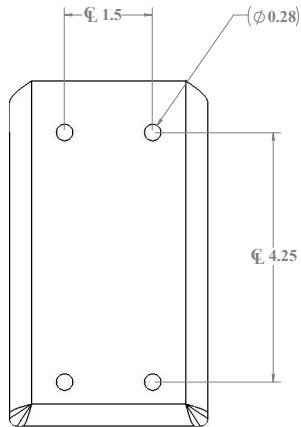
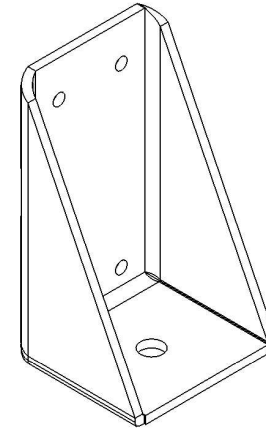
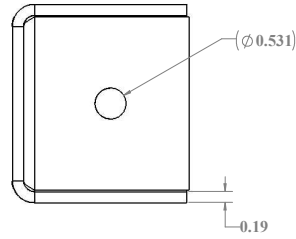

WEB DRAWING (NOT FOR FABRICATION)

UNLESS OTHERWISE SPECIFIED:		NAME	DATE	DDB Unlimited Inc.			
Model by:	DATE			20D-MTFT			
Drawn by:	DATE			Foot Mounting Exterior, 20D-30D-WOOD (ZP-20D-MTFT)			
SALES REP.:	DATE			SIZE	Code	DWG. NO.:	REV
Q.A. Appr.:	DATE			D	385YS	02578	A
Prod.Mgr.:	DATE			SCALE: 1:1	WEIGHT: 1 lbs.	SHEET 1 OF 2	

UNCLASSIFIED PUBLIC

DDB FORM 7.1-2 REV.F 05/02/19

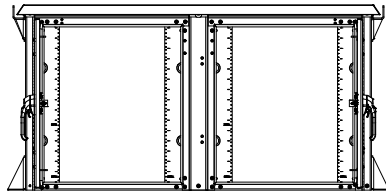

FOR VISUAL

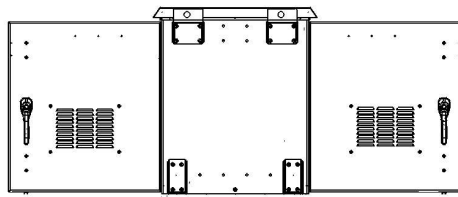
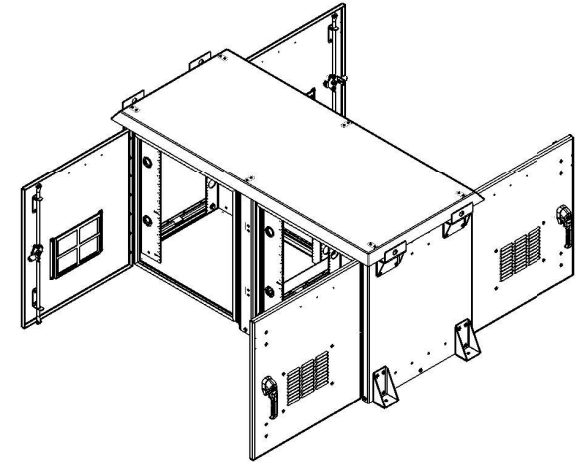

$(2 \times \frac{15}{16}'')$

$(\frac{7}{8}'')$

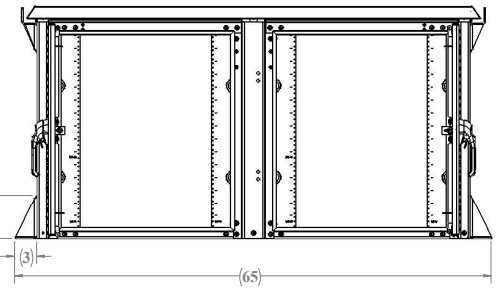

20D-30DX SHOWN

UNLESS OTHERWISE SPECIFIED:		DDB Unlimited Inc.			
DIMENSIONS ARE IN INCHES		20D-30DX			
FINISH	POUNDS PER SQUARE FOOT	SIZE	Case Code:	DWG. NO.:	REV
STAINLESS STEEL	1.00	D	385YS	02578	A
PAINT:	UNLESS OTHERWISE SPECIFIED	SCALE	1:10	WEIGHT: 218 lbs.	SHEET 2 OF 2
DO NOT SCALE DRAWING					

UNCLASSIFIED PUBLIC
 THE INFORMATION CONTAINED IN THIS DRAWING IS THE SOLE PROPERTY OF DDB Unlimited, INC. ANY REPRODUCTION IN PART OR AS A WHOLE WITHOUT THE WRITTEN PERMISSION OF DDB Unlimited, INC. IS PROHIBITED.

File Location: (DDB)\EPM\Vault1
 C:\DDB\Drawing Requests\Customers\20D WEB DWG\Brackets of all types\20D-MTF

DDB FORM 7-1-2 REV/AK 08/02/17