

Y GD'FTCY RPI 'PQVHQTHCDTIECVIQP+

TGXHQPU		
TGX0	FGUETRVIQP	FCVG
C	DQF/FZ	8E H243

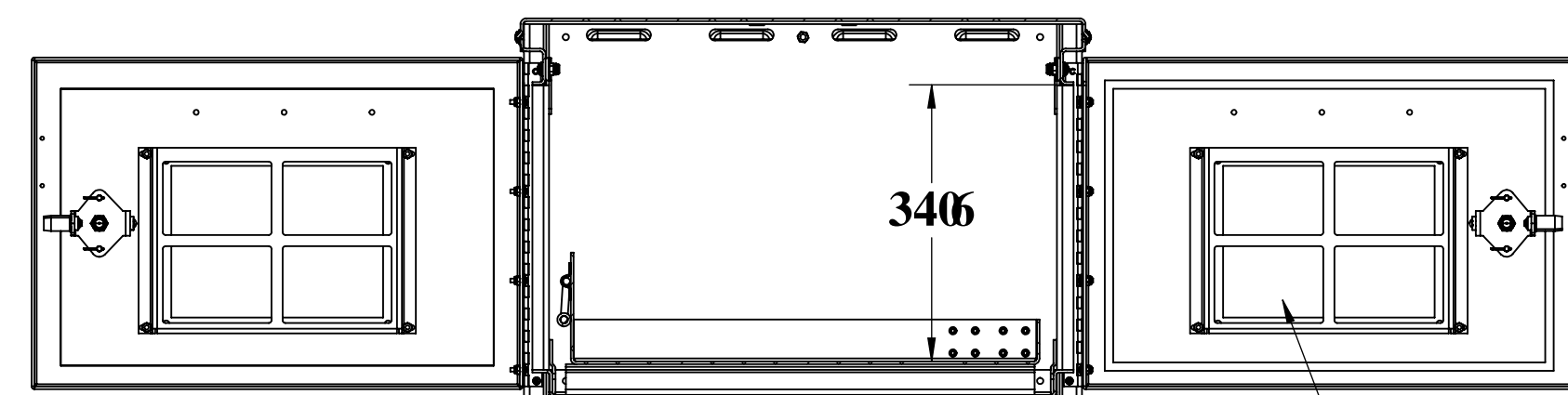

UGEVIQP'C/C

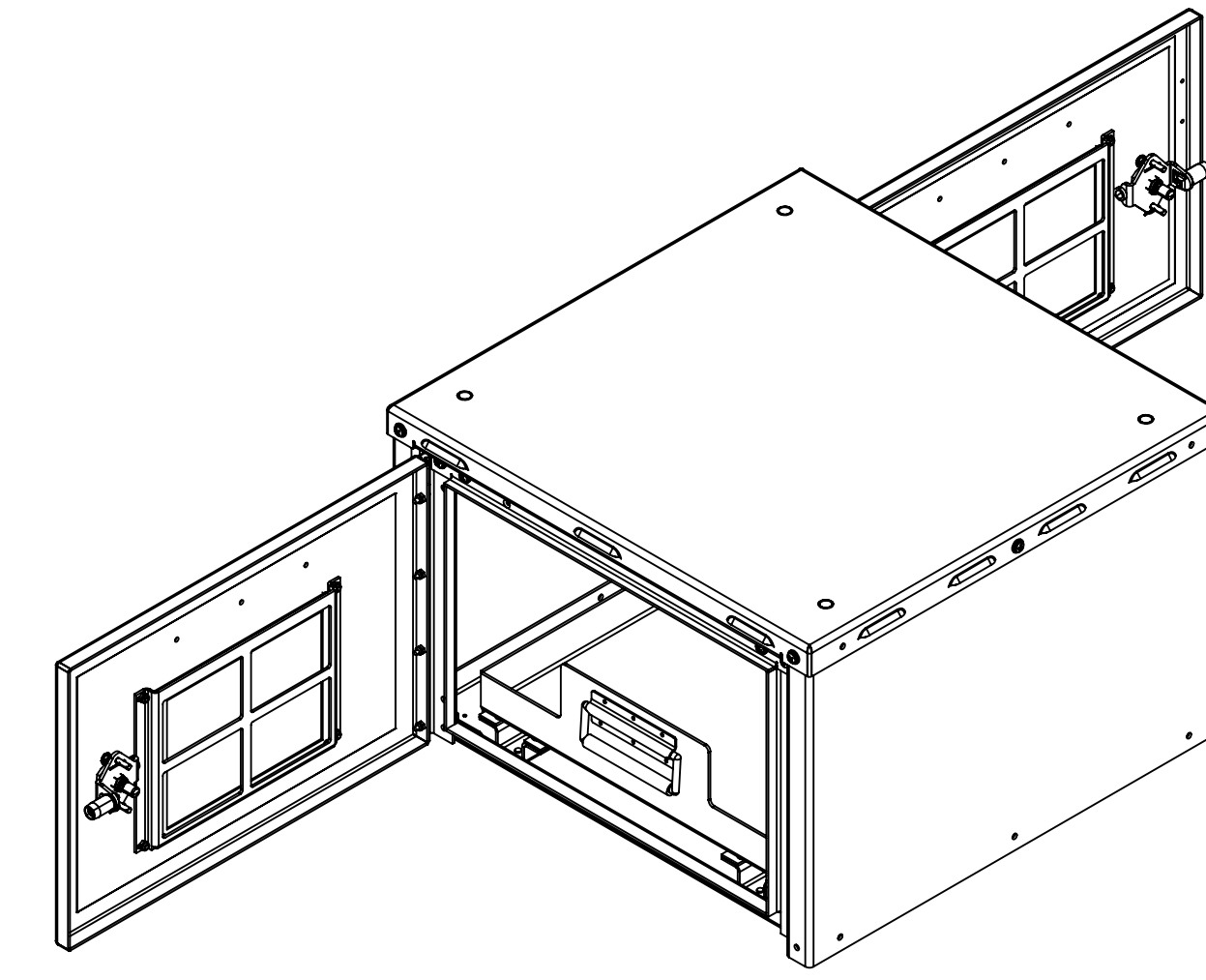
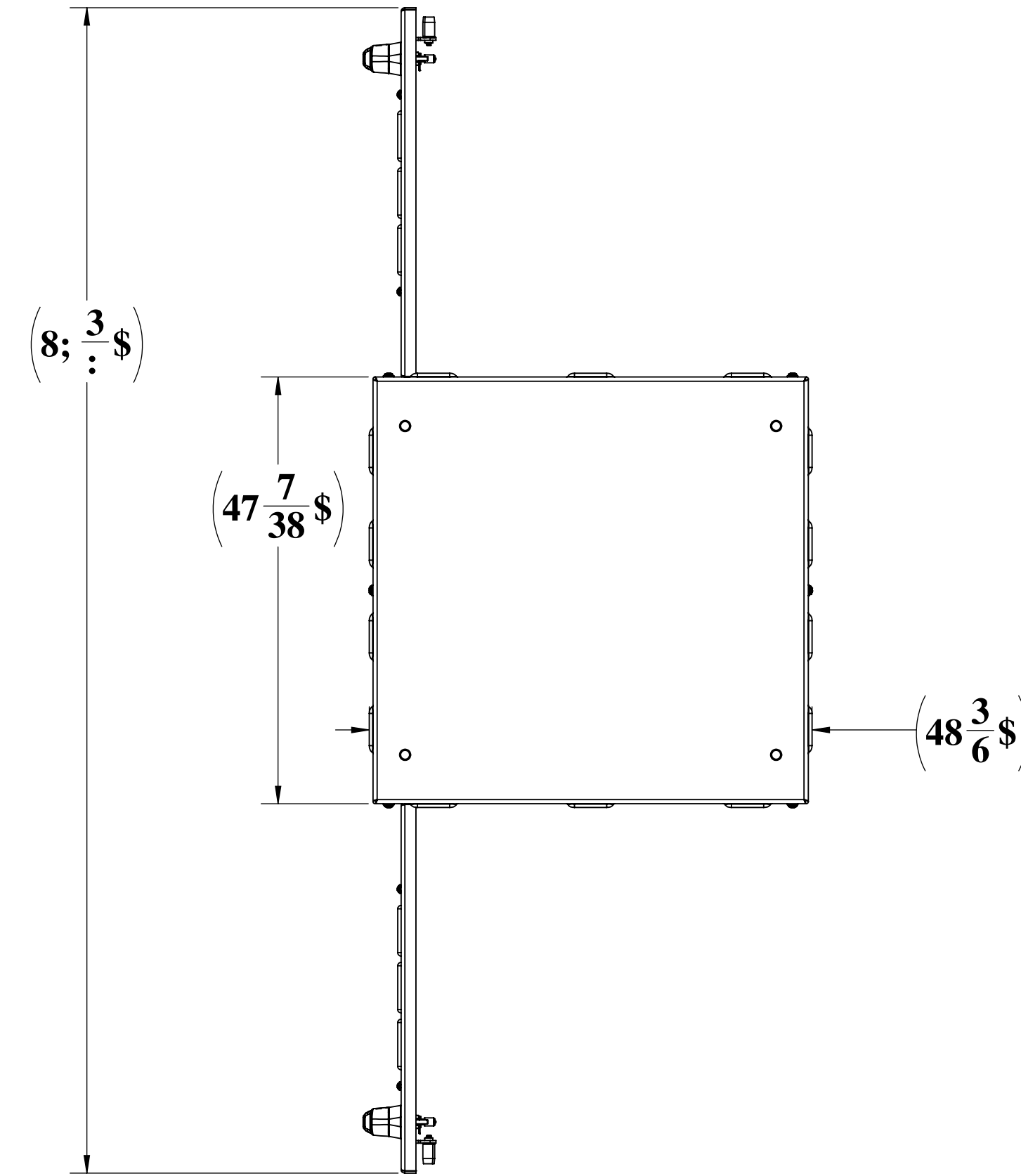
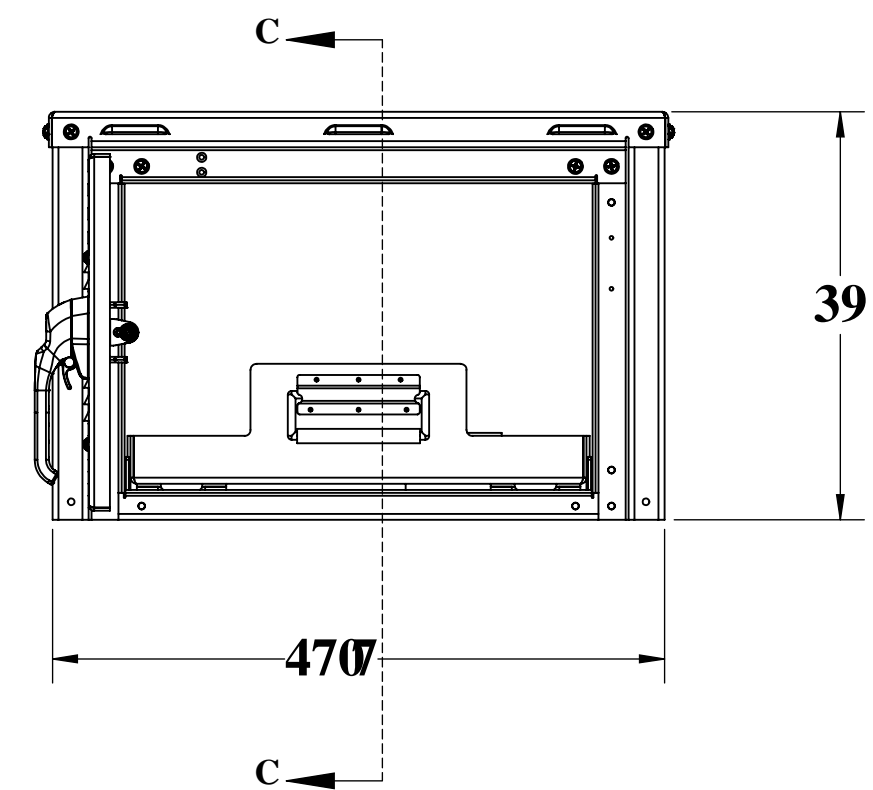

NQWXGTU  
CPF'HRNVGT  
DTCEMGVU

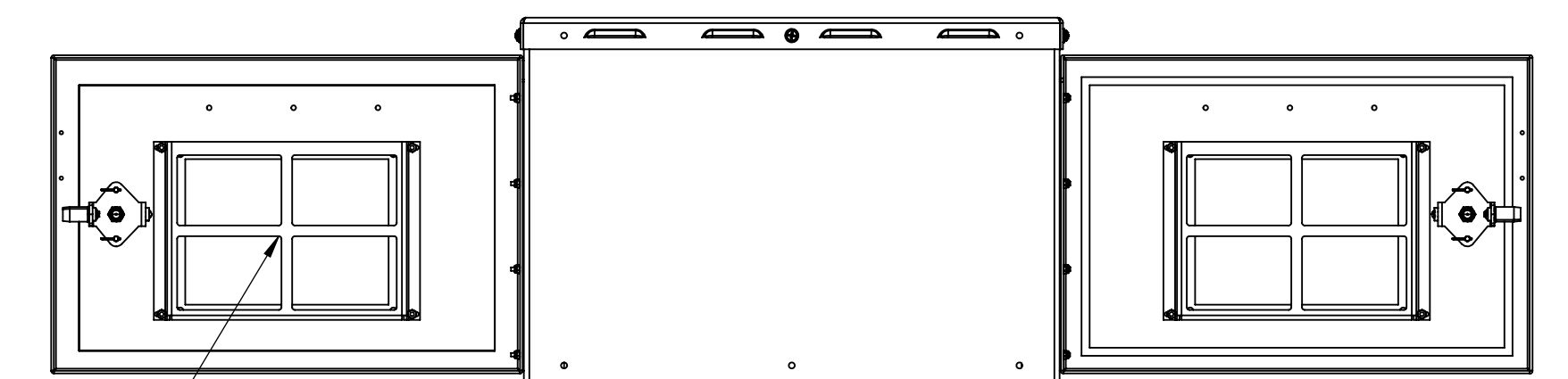

NQWXGTU  
CPF'HRNVGT  
DTCEMGVU

Y GD'FTCY RPI 'PQVHQTHCDTIECVIQP+

WNGU'QJ GTV HCURGEHGF<		PCOG	FCVG	FFD'Wpilo ksf 'Ipe0				
FKGFKU'KTUW'WELI'U		O qf glll<	FFD	DQF				
CPI WCT- 11*		Ftey p'0l<	OotspU	Dqr.'Devgl.'TQF.'FZ'''				
HCUVQPCN'OP'EGJCM'''20471		Ungof'gr'c		GA9	7 U[ Y 7 cXY.	8K ; " BC".	F9J	
QV'ORL'EG'EGJCM'''20481		S'ICU'Cr't'c	4qI	28D; H3				
V'IGOR'EG'EGJCM'''20491		R'q'f'0'1'0:	Ext'ml	28D; H3	8	'.)M	\$&*) (	5
V'IGOR'EG'EGJCM'''20501		E'gr'ep'p'w'q'c<			G7 5.69 %.	K 9# <H''%Vg	G-99H9C: &	
CNI'ON'EG'EGJCM'''20511								
O'CVG'ICN: 7274/1 54/26475'CUVO/D42;/26								
R'CR'V'c: F'KO'OFF'301'ON'908'G1'50'UN'V'Z'W'V'OD'541								
F'Q'P'Q'V'U'EC'NG'F'CY'R'P'1								

F F D H Q I O 2908/4 T G X H 27124B3

Y GD'FTCY RPI 'PQVHQTHCDTIECVIQP+

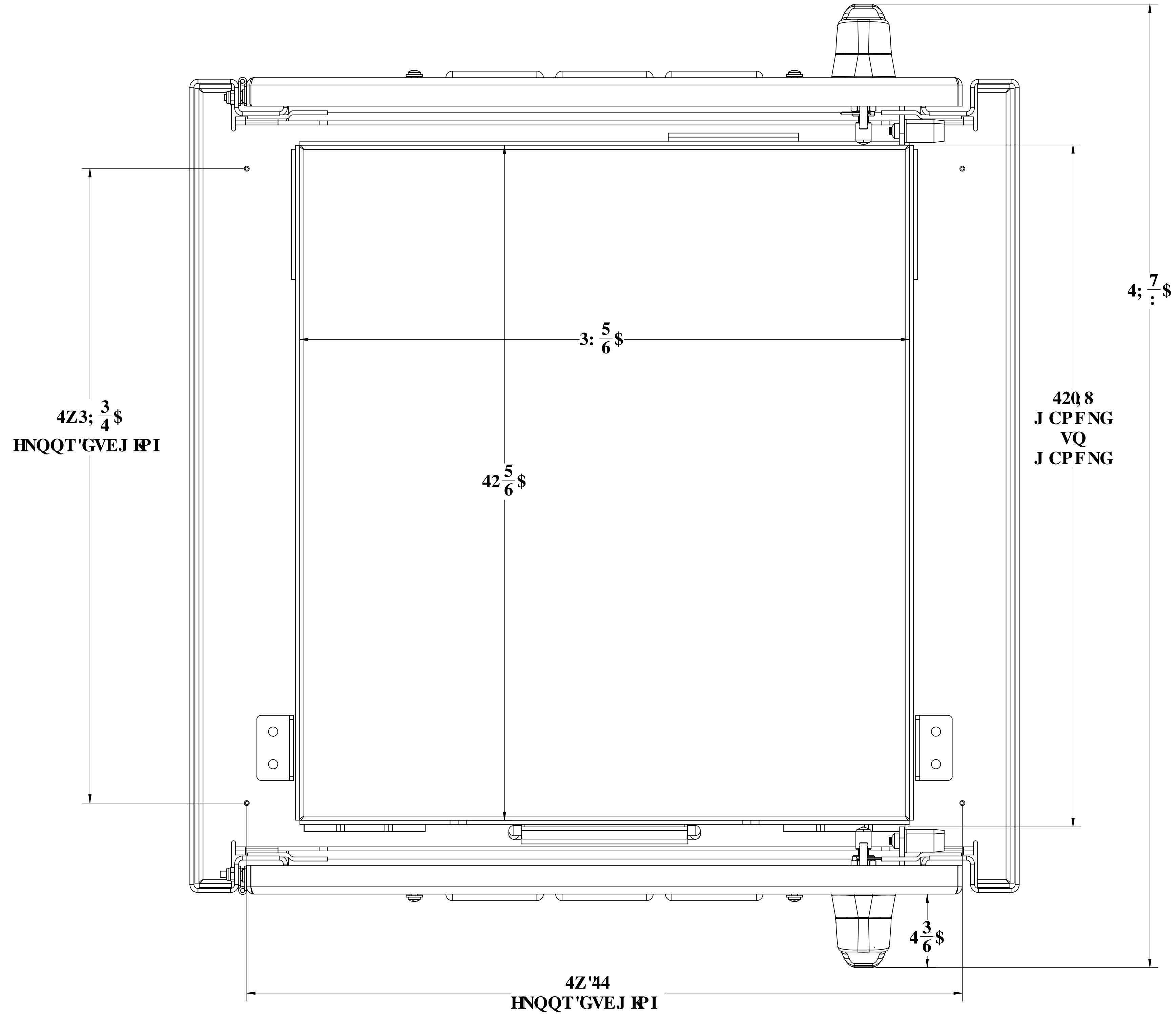

VQR'XKGY 'EGNRPI 'PQV'UJ QY P

WPENCUIHKGF'RWDNIE

Y GD'FTCY RPI 'PQVHQTHCDTIECVIQP+

WNGU'QJ GY RUCRZHBGP<	PCOG	FCVG	FFD'Wplo ksf 'Ipe0				
FKQFQKUTUR WELU	O qf gll<	FFD	DQF				
CPI WCT	Ftey p'bl<	Oetkpu	Dqr, Dvngl, 'QF, 'FZ''				
HCEVQPCNFQF'EGJCM	Ungof grlc						
QVORLEJ'EGJCM	SICUCrtlc	4qI	28D, H3	GA9	7 U[ Y c XY.	8K ; " BC"	F9J
VJ'ORLEJ'EGJCM	Rqf'ID110:	ExtmI	28D, H3	8	' , ) M	\$&*) (	5
VJ'ORLEJ'EGJCM	Egrqf'w'qg<			G7 5.69 %	K 9e <H' %Vg	G-99H.C: &	

FFD'HQIO '908/4T GX'F' 27DAB;