

SOD Series- UL Listed

SOD-102420-UL50



Why Choose the SOD Series-UL Listed?

The SOD-102420-UL50 enclosure stands as a top choice for outdoor equipment racking, offering unparalleled versatility. Constructed with our Alumiflex® material, it is notably lighter than steel yet strong enough to rack the heaviest equipment with ease. The SOD-UL50 series boasts effortless installation and provides pad, pole, and wall mounting options for endless placement possibilities. As shown in Type 4 configuration (w/o vents), the SOD-UL series is also available in a Type 3R configuration (with vents). With standard features like a pad locking handle, built in solar cap to manage heat loads, door grounding straps, and UL-listed gasketing, the SOD-UL's value is unmatched. Adding to the flexibility, the SOD-UL series is configurable to be used for in indoor and outdoor applications and has an extensive list of available options, including climate controls, electrical and cable entry solutions. All of this comes with the industry's best lead times, unmatched warranty and competitive pricing. As expected, the DDB SOD-UL50 series sets the mark as a design leader that is versatile and scalable to meet a wide array of situations. Contact our knowledgeable sales team for more information.



Application Types

Provides A Secure Climate Controlled
Environment for any Electronic Equipment

- Telecommunications
- Wireless/Broadband
- DAS/BDA
- Fiber Optics
- Back Haul
- Base Station
- Small Cell
- Utility-Traffic
- Trailer-Based Communications
- Wi-Fi
- Flexible and Scalable



Environmental & Safety Ratings:

- ✓ UL Listed
- ✓ Type 4 shown (w/o vents)
- ✓ Type 3R available (with vents)

Features

- 15 Year Warranty
- 0.125" Aluminum Construction
- Pad Locking System
- Heavy Duty Construction with Front Door Access
- Standard Lifting Hooks
- Stainless Steel External Hardware/Hinge
- Cream Powder- Coat, Standard
- Quick Shipping

Weight and Dimensions

- Approximate Exterior Enclosure Dimensions:
12"H x 24"W x 24"D
- Shipping Dimensions:
30"L x 30"W x 16"H- Boxed
- Approximate Shipping Weight:
45 lbs.

SOD Series- UL Listed

SOD-102420-UL50



Believing in American
Craftsmanship

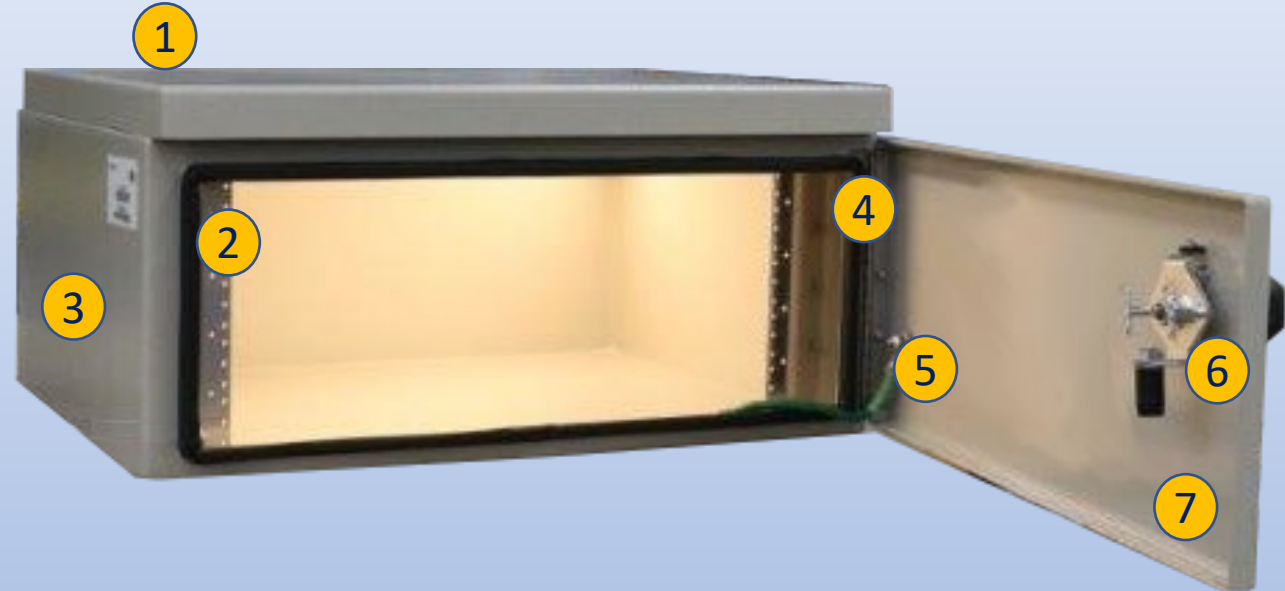

Features

1. Solar Cap
2. 19" Racking Rails
3. Powder-Coat Cream
4. Stainless Steel Door Hinge
5. Door Grounding Straps
6. Pad Locking Handle
7. 0.125" Aluminum Construction

2301 S. HWY 77 Pauls Valley, OK 73075
T: (405)-665-2876

sales@ddbunlimited.com www.ddbunlimited.com

Scan this code for
Accessories



REVISIONS		
REV.	DESCRIPTION	DATE
A	WEBSITE DRAWING PER DR-02036	6/5/2019
B	UPDATED SHEET FORMAT PER DR-03254. CHANGED SEVERAL DECIMAL DIMENSIONS TO COMMON FRACTIONS.	8/15/2024

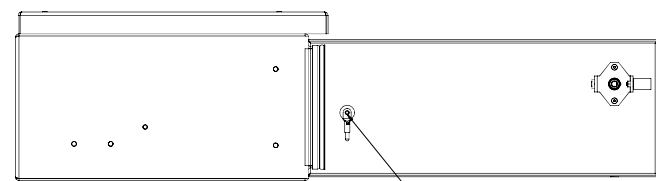
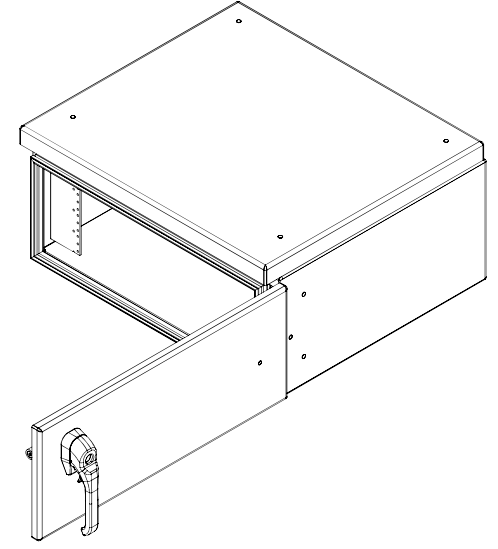
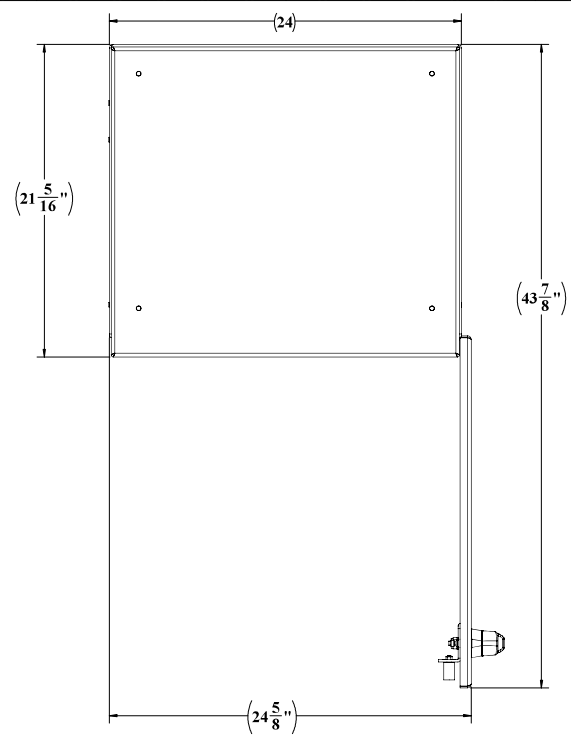

GROUNDING STUD & PAINT FREE AREA

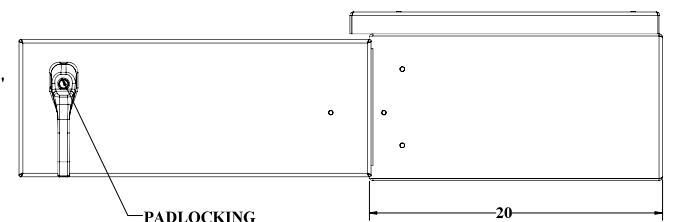
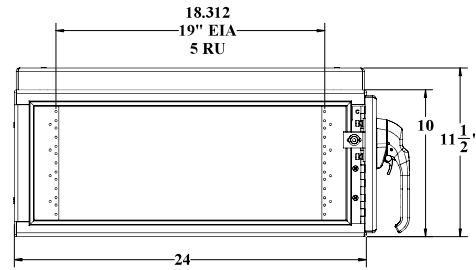

PADLOCKING HANDLE

UNLESS OTHERWISE SPECIFIED:			
DIMENSIONS ARE IN INCHES		SOD-102420-01150	
APPROXIMATE WEIGHT	32 lbs	SHEET	02036
APPROXIMATE HEIGHT	43 7/8"	CODE	28515
APPROXIMATE DEPTH	10 1/2"	DWG. NO.	02036
APPROXIMATE WIDTH	24"	REV.	B
MATERIALS SPECIFIED BY ALTA BIPROSA		SCALE: 1:12 WEIGHT: 32 lbs. SHEET 1 OF 2	
PAINT: GROUNDING STUD: BULGARDI 11-12-13			
DO NOT SCALE DRAWING			

UNCLASSIFIED PUBLIC

DDB FORM 7.1-2 REV A 08/02/17

8 7 6 5 4 3 2 1

H
G
F
E
D
C
B
A

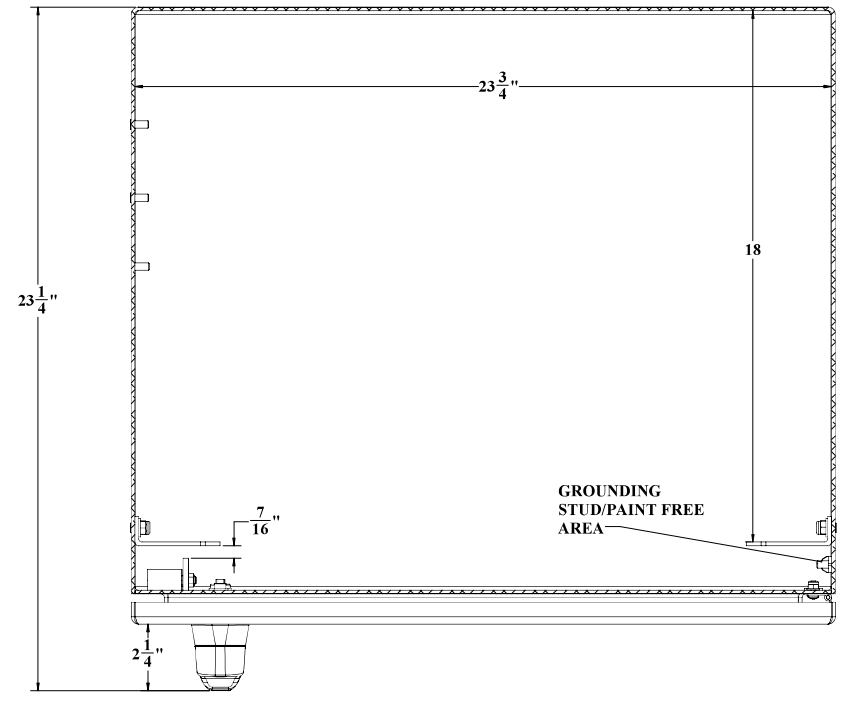
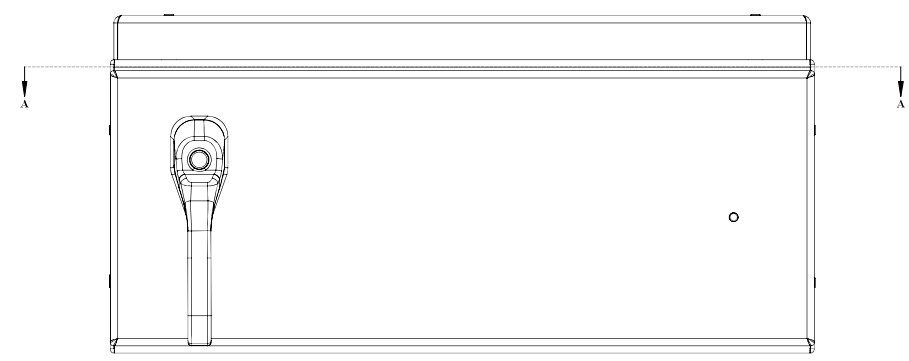

SECTION A-A
SCALE 1 : 2

UNCLASSIFIED PUBLIC

UNLESS OTHERWISE SPECIFIED:			
DESCRIPTION	UNIT		
WELDED JOINTS	1/8"		
DRILLING TOLERANCE	±0.005		
TRAFFIC LIGHTS	±0.005		
DRILL HOLE TOLERANCE	±0.005		
ALL DIMENSIONS ARE UNLESS OTHERWISE SPECIFIED			
MATERIAL SPECIFIED BY CUSTOMER	ALUMINUM		
PAINT SPECIFIED BY CUSTOMER	PAINT		
DDB UNLIMITED INC.			
SDD-102420-11.59-Dura Closed White Only			
REV	Code Code:	DWG. NO.:	REV
D	28515	02036	8
SCALE: 1:12		WEIGHT: 31 lbs.	SHEET 2 OF 2

DDB FORM 7.1-2 REV A 08/02/17