



## Why Choose the ST Series?

The ST series of enclosures are the ultimate choice for your indoor racking requirements. Being made of our own rugged Alumiflex®, you'll find it noticeably lighter than steel, yet strong enough to rack even the heaviest equipment. When choosing the ST series, you have handpicked the highest value in American construction. The ST-42DX includes the standard features you have come to expect with DDB, incorporating the versatile strut system for adjustable racking, the security of a lockable slam-latch system and easy clean filters. For those who need more than just our standard enclosure, DDB can also make a truly customized solution with our many available options including fan kits, heater strips, mounting trays, & cable management. All of this comes together to create an enclosure able to meet all of the unique needs our customers have been seeking. DDB offers a state-of-the-art design, a competitive price, benchmark lead times and a guaranteed delivery, all backed up with an industry leading 15-year warranty on every enclosure. Put DDB's substantial stock to work for you today. Contact our professional staff to assist you with your made-to-order solution.



### Features

- 15 Year Warranty
- 0.100" Aluminum Construction
- Stainless Steel External Hardware/Hinge
- Lockable Slam-Latch
- Heavy Duty Indoor Construction
- Front and Rear Access
- Cream Powder-Coat, Standard
- Flexible and Scalable
- Quick Shipping

### Application Types

- |                             |              |
|-----------------------------|--------------|
| Telecommunications          | Utility      |
| Wireless/Broadband          | Military     |
| Fiber Optics                | Base Station |
| Data Centers                | Backhaul     |
| Server rooms                | Wi-Fi        |
| Small Cell/DAS              | LTEE/4G/5G   |
| Trailer-Base Communications |              |
| Public Safety               |              |



### Environmental & Safety Ratings:

✓ NEMA 2

### Weight and Dimensions

- Approximate Exterior Enclosure Dimensions:  
44"H x 23"W x 25"D
- Shipping Dimensions:  
32"W x 42"L- Palletized
- Approximate Shipping Weight:  
103 lbs.

2301 S. HWY 77 Pauls Valley, OK 73075

T: (405)-665-2876

[sales@ddbunlimited.com](mailto:sales@ddbunlimited.com) [www.ddbunlimited.com](http://www.ddbunlimited.com)

# ST Series

## ST-42DX



### Features

1. 0.100" Aluminum Construction
2. Lockable Slam-Latch
3. Reusable Foam Filters
4. Stainless Steel Door Hinge
5. 19" Adjustable Racking Rails
6. Rear Door Access
7. Powder Coat Cream

Scan this code for  
Climate Control



Scan this code for  
Accessories



2301 S. HWY 77 Pauls Valley, OK 73075  
T: (405)-665-2876

[sales@ddbunlimited.com](mailto:sales@ddbunlimited.com) [www.ddbunlimited.com](http://www.ddbunlimited.com)

8 7 6 5 4 3 2 1

H  
G  
F  
E  
D  
C  
B  
A

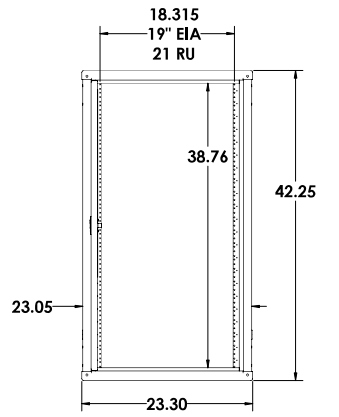
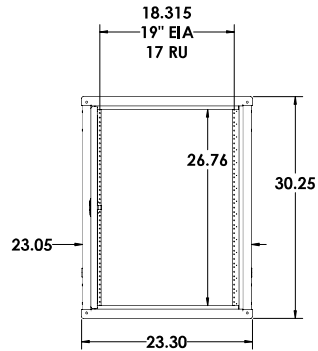
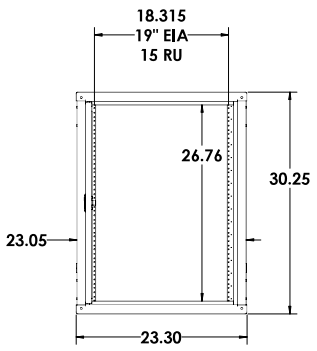
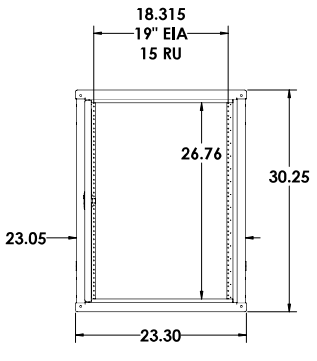
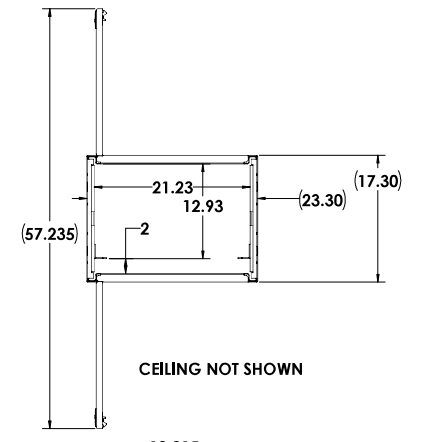
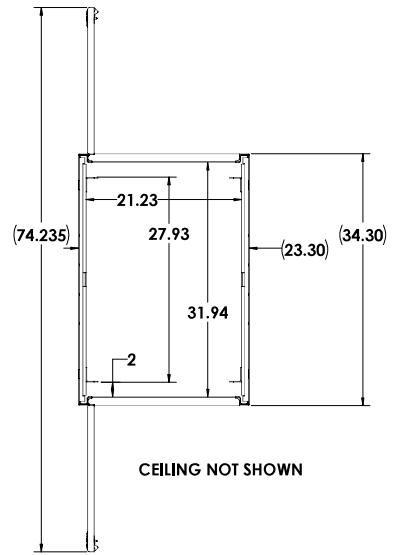
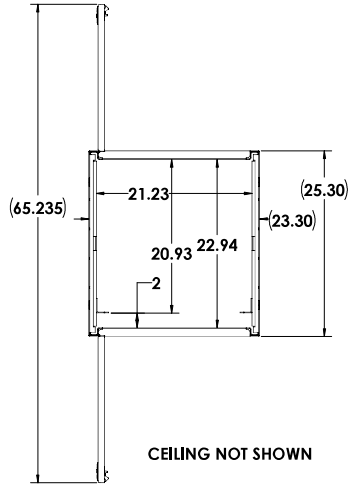
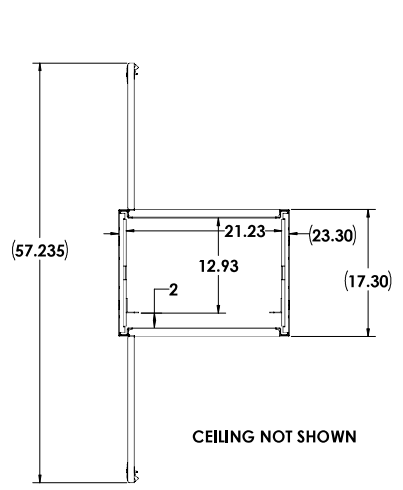

ST-30D

ST-30DX

ST-30DD

IOD-42D

- 30D DIAMOND VOGEL, BEIGE GLOSS TEXTURE ET-8320
- 30DX DIAMOND VOGEL, BEIGE GLOSS TEXTURE ET-8320
- 30DD DIAMOND VOGEL, BEIGE GLOSS TEXTURE ET-8320
- 42D DIAMOND VOGEL, BEIGE GLOSS TEXTURE ET-8320
- 42DX DIAMOND VOGEL, BEIGE GLOSS TEXTURE ET-8320
- 42DD DIAMOND VOGEL, BEIGE GLOSS TEXTURE ET-8320
- 62DXB DIAMOND VOGEL, BLACK RIVER TEXTURE ET-9384

<small>UNLESS OTHERWISE SPECIFIED: DIMENSIONS ARE IN INCHES</small>		<b>DDB Unlimited Inc.</b> 300	
<small>PROJECT: DRAWING NO. AND REVISION: 01/17/24 DATE OF ISSUE: 01/17/24 SCALE: 1/8" = 1'-0" SHEET NO. AND TOTAL: 1 OF 4</small>	<small>DATE: DRAWN BY: CHECKED BY: APP.:</small>	<small>REV. NO.:</small> D <small>SCALE:</small> 1/8" = 1'-0" <small>WEIGHT:</small> 47 lbs.	<small>REV. DATE:</small> E <small>SHEET:</small> 3 OF 4
<small>DO NOT SCALE DRAWING</small>			

UNCLASSIFIED PUBLIC

01/19/24

